

Preliminary

Stormwater Management Report Ospringe Development, Wellington County



Prepared for Spirit of Pentecost
by IBI Group

December 22, 2021

Document Control Page

CLIENT:	Spirit of Pentecost
PROJECT NAME:	Ospringe Development, Wellington County
REPORT TITLE:	Stormwater Management Report Ospringe Development, Wellington County
IBI REFERENCE:	111618
VERSION:	
DIGITAL MASTER:	[\\caneast.ibigroup.com\J\HM\111618_OspringeErin\5.0 Design (Work) Phase\SWM\December 2021\CTR_Preliminary_SWM_2021-12-23.docx\2021-12-22\AK]
ORIGINATOR:	
REVIEWER:	
AUTHORIZATION:	
CIRCULATION LIST:	
HISTORY:	

Table of Contents

1	Introduction	1
2	Existing Conditions	1
3	Proposed Conditions	1
4	Stormwater Management	2
4.1	Stormwater Quantity Control	2
4.2	Overland Flow.....	4
4.3	Stormwater Quality Control.....	4
5	Monitoring and Maintenance	5
6	Conclusions and Recommendations	5

List of Figures

- Figure 1 – Location Map
- Figure 2 – Existing Conditions SWM Areas
- Figure 3 – Proposed Conditions SWM Areas

Table of Contents (continued)

List of Tables

Table 1 – MIDUSS Modelling Variables	2
Table 2 – Rainfall Depths.....	3
Table 3 – Peak Flows	3
Table 4 – Tank Characteristics	4

List of Appendices

Appendix A – Preliminary Stormwater Calculations
Appendix B – Preliminary MIDUSS Model Output

1 Introduction

IBI Group was retained to prepare a Preliminary Stormwater Management Report for the Ospringe Development in Wellington County. The subject land is legally described as Part of Lot 13 Concession 2 Erin as in MS126136 (Fourthly) Except Part 1, Plan 61R-6497 Ospringe Settlement Area Wellington County Ontario. The property is 3.62 hectares in area and is located at the northwest intersection of Highway 124 (Wellington County Road 124) and Second Line (Wellington County Road 125) in the Settlement Area of Ospringe (refer to Figure 1). The development is proposed to contain 13 residential lots and a stormwater management facility.

The purpose of this Report is to address the appropriate stormwater quantity and quality requirements, in accordance with the criteria set out and comments provided by Wellington County.

2 Existing Conditions

The 3.62ha property is used for agricultural purposes and is bounded by residential lots to the east and west, and agricultural lands to the north. The property is characterized by hilly topography with slopes of approximately four percent.

A 0.382 ha area at the northwest corner of the property drains overland toward agricultural lands to the west. The remainder of the site drains overland toward the east to the intersection of Highway 124 and Second Line. Runoff then enters a 375mm diameter storm sewer on Second Line via a road catch basin, which then continues northeast along Highway 124. Existing conditions drainage areas are shown in Figure 2.

Based on the borehole logs provided by CVD Engineering Limited, soils on site are typically silty sand, sand and gravel, and sandy silt. Seasonally high groundwater levels are typically within one metre below the ground surface.

3 Proposed Conditions

The subject lands are proposed to contain 13 single-family residential lots. The impervious area of the development includes paved roads, single-detached houses, driveways, and various other hard surfaces. The total impervious coverage of the developing areas was estimated to be approximately 30 percent. The external area to the northwest will continue to drain through the site via swales and ditches. Proposed conditions drainage areas are shown on Figure 3.

The proposed development will drain to an underground storage tank to be located at the northeast portion of the site, and then continue to outlet toward the existing storm sewer on Second Line. The tank will provide stormwater quantity control for the developing area. Minor flows will be conveyed to the stormwater management tank via grass ditches, and major flows will be conveyed to the tank via the road network and grass ditches. Stormwater quality control will be provided using grass ditches and an oil/grit separator (OGS) unit.

A 0.337 ha area at the northwest portion of the site consisting of rear lots areas will continue to drain toward the west.

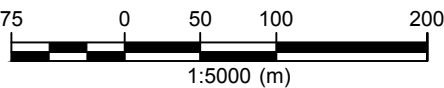
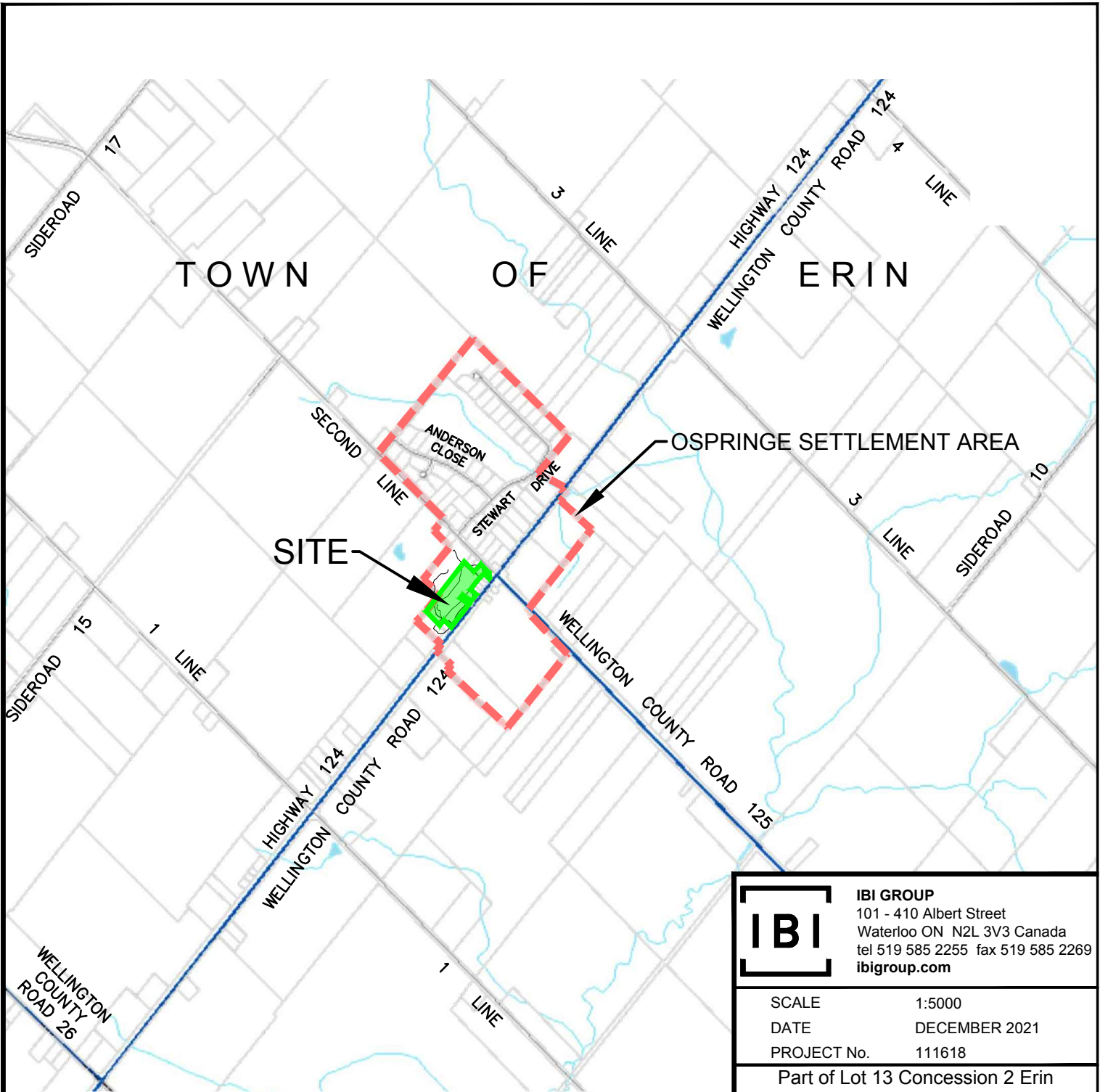

	IBI GROUP 101 - 410 Albert Street Waterloo ON N2L 3V3 Canada tel 519 585 2255 fax 519 585 2269 ibigroup.com
	SCALE 1:5000 DATE DECEMBER 2021 PROJECT No. 111618
	Part of Lot 13 Concession 2 Erin as in MS126136 (Fourthly) Except Part 1, Plan 61R-6497 Ospringe Settlement Area Wellington County ON
OSPRINGE DEVELOPMENT WELLINGTON COUNTY	
SITE LOCATION	
FIGURE 1	

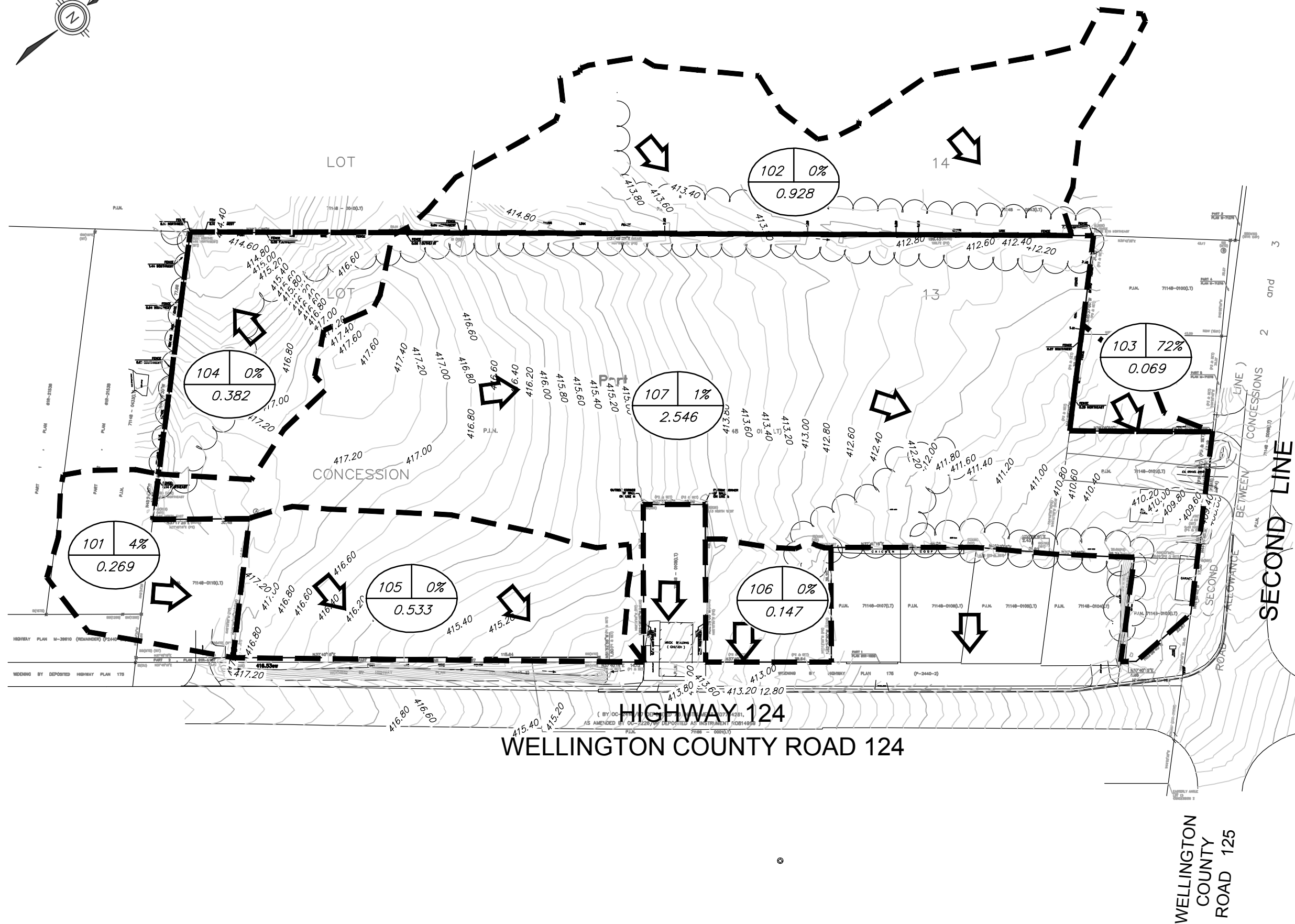

LEGEND

- EXISTING TREELINE
- - - EXISTING FLOODLINE
- - - EXISTING CATCHMENT BOUNDARIES
- EX. CATCHMENT SYMBOL
○ CATCHMENT AREA NUMBER
- EX101 42%
○ 1.234 % IMPERVIOUS
○ AREA (ha)
- ⇨ EXISTING DRAINAGE FLOW PATTERN

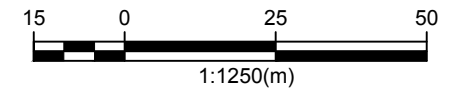

IBI GROUP
 101 - 410 Albert Street
 Waterloo ON N2L 3V3 Canada
 tel 519 585 2255 fax 519 585 2269
 ibigroup.com

SCALE 1:1250
 DATE DECEMBER 2021
 PROJECT No. 111618

Part of Lot 13 Concession 2 Erin
 as in MS126136 (Fourthly)
 Except Part 1, Plan 61R-6497
 Ospringe Settlement Area
 Wellington County ON

**OSPRINGE DEVELOPMENT
 WELLINGTON COUNTY**

**EXISTING CONDITIONS
 SWM AREAS**

FIGURE 2

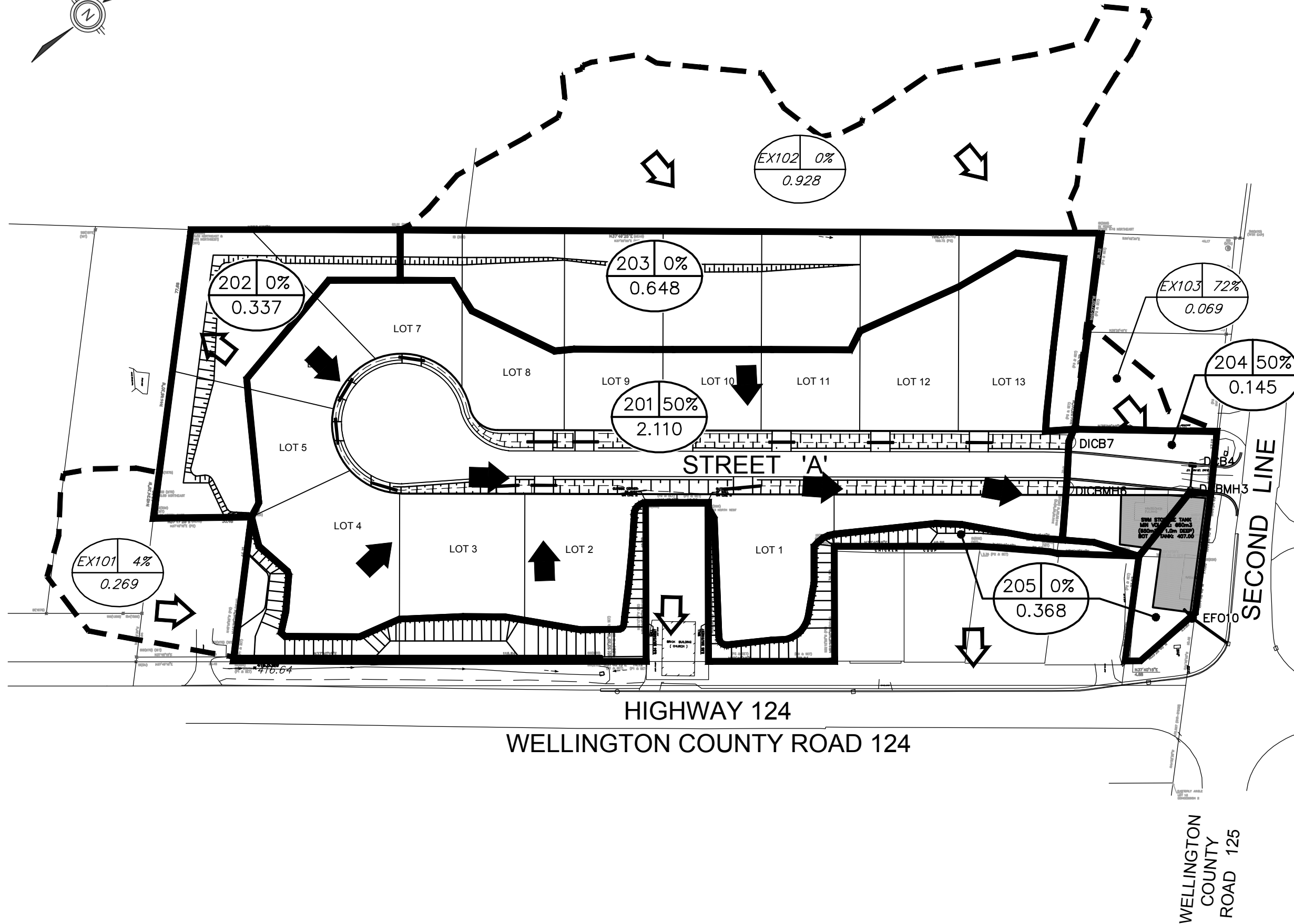

LEGEND

- EXISTING TREELINE
- - - EXISTING FLOODLINE
- - - EXISTING CATCHMENT BOUNDARIES
- PROPOSED CATCHMENT BOUNDARIES
- PROP. CATCHMENT SYMBOL
CATCHMENT AREA NUMBER
- EX. CATCHMENT SYMBOL
CATCHMENT AREA NUMBER
- ◀ PROPOSED DRAINAGE FLOW PATTERN
- ◀ EXISTING DRAINAGE FLOW PATTERN

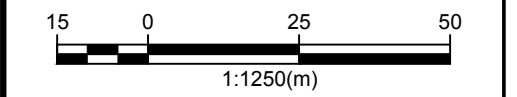

IBI GROUP
 101 - 410 Albert Street
 Waterloo ON N2L 3V3 Canada
 tel 519 585 2255 fax 519 585 2269
 ibigroup.com

SCALE 1:1250
 DATE DECEMBER 2021
 PROJECT No. 111618

Part of Lot 13 Concession 2 Erin
 as in MS126136 (Fourthly)
 Except Part 1, Plan 61R-6497
 Ospringe Settlement Area
 Wellington County ON

**OSPRINGE DEVELOPMENT
 WELLINGTON COUNTY**

**PROPOSED CONDITIONS
 SWM AREAS**

FIGURE 3

4 Stormwater Management

The stormwater management criteria for this development have been set based on requirements of and discussions with Wellington County. The requirements include:

- Stormwater quantity controls are required for the site to control the proposed conditions flows from the site to the existing conditions for events from the 5 year to the 100 year storm; and
- Stormwater quality control is to be provided for the developing area for an Enhanced Protection Level.

4.1 Stormwater Quantity Control

Based on the stormwater quantity criteria, proposed development peak flows are to be controlled to existing conditions levels. Given the high groundwater elevations, the use of a surface pond for quantity control is not feasible. Quantity control will be provided within a 650 m³ underground storage tank, the location of which is shown in Figure 3 and on the grading plan. The preliminary stage-storage-discharge relationship of the tank is included in Appendix A.

Modelling was completed for the development using the MIDUSS computer program (refer to Appendix B for model output). Key modelling variables are summarized in Table 1.

Table 1 – MIDUSS Modelling Variables

CATCHMENT ID	LAND USE DESCRIPTION	AREA (HA)	LENGTH* (M)	GRADIENT %	IMPERVIOUS %	PERVIOUS CN	MANNING N
Existing Conditions							
101	Residential Lot	0.269	20	2	4	71	0.25
102	Agricultural	0.928	30	4	0	71	0.25
103	Residential Lot	0.069	10	2	72	71	0.25
104	Agricultural	0.382	20	4	0	71	0.25
105	Agricultural	0.533	20	4	0	71	0.25
106	Agricultural	0.147	20	4	0	71	0.25
107	Agricultural	2.560	50	4	1	71	0.25
Total		4.89			1.8		
Proposed Conditions							
101	Residential Lot	0.269	20	2	4	71	0.25
102	Agricultural	0.928	30	4	0	71	0.25
103	Residential Lot	0.069	10	2	72	71	0.25
201	Residential Lots	2.110	20	4	50	71	0.25
202	Residential Lots	0.337	20	4	0	71	0.25
203	Residential Lots	0.648	20	4	0	71	0.25
204	Residential Lots	0.145	10	2	10	71	0.25
205	Residential Lots	0.368	10	10	0	71	0.25
Total		4.89			23.1		

Three-hour duration Chicago storms based on the Fergus Shand Dam intensity-duration-frequency (IDF) curves was used for the hydrologic modelling. The total depth of rainfall for the 5, 10, 25, 50, and 100 year storms and for the Regional Storm are summarized in Table 2.

Table 2 – Rainfall Depths

RETURN EVENT	DEPTH (mm)
5 Year	49.0
10 Year	60.1
25 Year	73.6
50 Year	83.4
100 Year	93.5
Regional	212.0

Based on preliminary discussions with the Geotechnical Engineer (CVD Engineering Ltd.), the stormwater storage tank will be partially within the seasonally high groundwater at its upstream limit, and will need to be anchored to prevent any hydrostatic impacts.

A 225mm diameter orifice control and a 2.0m wide weir at the tank outlet manhole will provide stormwater attenuation. Peak flows for existing and proposed conditions are summarized for the east draining and west draining areas in Table 3, and the characteristics of the stormwater management tank are provided in Table 4.

Table 3 – Peak Flows

RETURN EVENT	EXISTING CONDITIONS (m ³ /s)	PROPOSED CONDITIONS (m ³ /s)
Draining East		
5 Year	0.144	0.144
10 Year	0.251	0.215
25 Year	0.413	0.315
50 Year	0.542	0.444
100 Year	0.692	0.649
Regional	0.627	0.615
Draining West		
5 Year	0.015	0.013
10 Year	0.025	0.022
25 Year	0.042	0.037
50 Year	0.055	0.049
100 Year	0.070	0.062
Regional	0.053	0.047

Table 4 – Tank Characteristics

RETURN EVENT	STORAGE (m ³)	ELEVATION (m)	DEPTH* (m)
5 Year	308	407.47	0.47
10 Year	421	407.65	0.65
25 Year	545	407.84	0.84
50 Year	592	407.91	0.91
100 Year	624	407.96	0.96
Regional	622	407.96	0.96

* Tank Outlet Invert = 407.00m.

As indicated in Table 3, proposed conditions flows for all storm events have been controlled to below existing levels for the east and west outlets. Additional details will be provided at the final design stage.

4.2 Overland Flow

The major flow (100 year) for the area draining from Catchments 102 and 203 to DIMH7 is 0.274 m³/s. Rear and side yard swales are proposed for Lots 7 to 13 at a minimum slope of 2 percent. At a depth of 0.32m this swale will convey the major storm (capacity calculations are provided in Appendix A). Flows will be routed to the site storm sewer system. A swale is proposed at the rear of Lot 4 and will outlet to the County Road 124 ditch.

4.3 Stormwater Quality Control

The criteria require that an Enhanced Protection Level for stormwater quality control be provided as outlined by the Ministry of Environment Stormwater Management Planning and Design Manual (MECP, 2003).

Based on an Enhanced Protection Level for the downstream receiver, stormwater quality control must be provided to achieve 80 percent Total Suspended Solids (TSS) removal efficiency for 90 percent of annual flows. A treatment-train approach will be provided for water quality control using an oil/grit separator (OGS) unit and additional polishing in the roadside ditches.

A Stormceptor OGS unit (EFO10) will be installed at the outlet of the tank to provide stormwater quality control for flows generated from the developing areas tributary to the SWM tank. The total developing drainage area to the OGS is 2.903 ha (areas 201, 203 and 204, average 36.8 percent impervious). Based on output from the Stormceptor software, an EFO10 unit will provide a TSS removal efficiency of 84 percent for greater than 90 percent of annual flows generated by lands tributary to the unit (refer to Appendix A).

The unit meets the Enhanced long-term suspended solids removal requirements (80 percent TSS removal efficiency for 90 percent of annual flows). The unit should be inspected and cleaned regularly (typically once every 12 months) as per the manufacturer's specifications. Although the unit by itself meets an Enhanced Protection Level, the treatment-train approach will provide additional tertiary treatment of runoff before it is discharged off site.

5 Monitoring and Maintenance

Monitoring and maintenance are necessary for stormwater management facilities to ensure their continued operation. These requirements for the stormwater management facilities are based on information provided in MECP 2003.

The stormwater management facilities should be inspected on a regular basis to ensure that they are operating as intended. The tank and the OGS unit should be inspected on an annual basis. The following items should be noted during the inspections:

- Any noticeable damage to structures (e.g., headwalls, outlet structures, maintenance access routes, etc.);
- If the tank is draining down over 48 hours;
- The OGS unit should be inspected and cleaned (as required) as per the manufacturer's recommendations.

Details will be provided at the final design stage.

6 Conclusions and Recommendations

This Preliminary Stormwater Management Report demonstrates that the proposed conditions for this development satisfy the requirements for stormwater management established by the review agencies. It has been demonstrated that both water quantity and quality objectives have been met as follows:

- Stormwater quantity controls will be provided to control proposed conditions peak flows to existing conditions levels; and
- Stormwater quality control will be addressed through the use of a treatment-train utilizing flow through roadside grass ditches and an OGS unit to provide Enhanced Protection Level.

Based on these conclusions, we recommend that this Preliminary Stormwater Management Report be approved by the Review Agencies, and that a Final Stormwater Management Report be prepared at the detailed design stage.

Yours truly

IBI GROUP

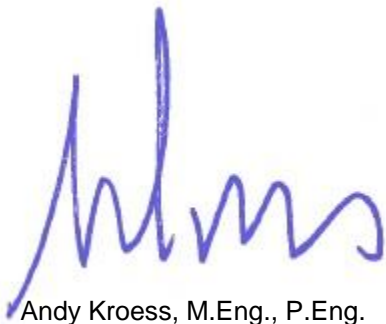

Andy Kroess, M.Eng., P.Eng.
Senior Water Resources Engineer

Appendix A – Preliminary Stormwater Calculations

**111618 - Ospringle Development, Wellington County
Preliminary Stormwater Management Tank Stage-Storage-Discharge Relationship**

Orifice # 1

Orifice Invert = 407.00 m (@ outlet)
 Orifice Radius = 0.1125 m
 Orifice Diameter = 225 mm
 Orifice Centreline = 407.113 m
 Orifice Coefficient = 0.6
 Orifice Area = 0.0397596 m²

Overland Spill

Weir Crest Elevation = 407.80 m
 Weir Length = 2.00 m
 Weir Coefficient = 1.6

Active Depth (m)	Elevation (m)	Description	Orifice # 1 Flow (m ³ /s)	Weir Flow (m ³ /s)	Total Flow (m ³ /s)	Active Storage (m ³)
0.00	407.00	Tank Invert	0.00000	0.00000	0.00000	0.0
0.10	407.10		0.02950	0.00000	0.02950	65.0
0.20	407.20		0.03125	0.00000	0.03125	130.0
0.30	407.30		0.04575	0.00000	0.04575	195.0
0.40	407.40		0.05665	0.00000	0.05665	260.0
0.50	407.50		0.06576	0.00000	0.06576	325.0
0.60	407.60		0.07376	0.00000	0.07376	390.0
0.70	407.70		0.08098	0.00000	0.08098	455.0
0.80	407.80		0.08760	0.00000	0.08760	520.0
0.90	407.90	Spill Elevation	0.09375	0.10119	0.19494	585.0
1.00	408.00		0.09953	0.28622	0.38574	650.0

Orifice equation: $Q = C_o \times A \times (2 \times g \times h)^{0.5}$

Weir equation: $Q = C_w \times L \times (H)^{3/2}$

where: A = orifice area (m²)

g = 9.806 m/s²

h = head above c/l of orifice (m)

L = weir length (m)

H = head above weir (m)

Cross Section for Rear Yard Swale

Project Description	
Friction Method	Manning Formula
Solve For	Normal Depth

Input Data	
Roughness Coefficient	0.045
Channel Slope	0.020 m/m
Normal Depth	319.7 mm
Left Side Slope	3.000 H:V
Right Side Slope	3.000 H:V
Bottom Width	0.00 m
Discharge	274.00 L/s

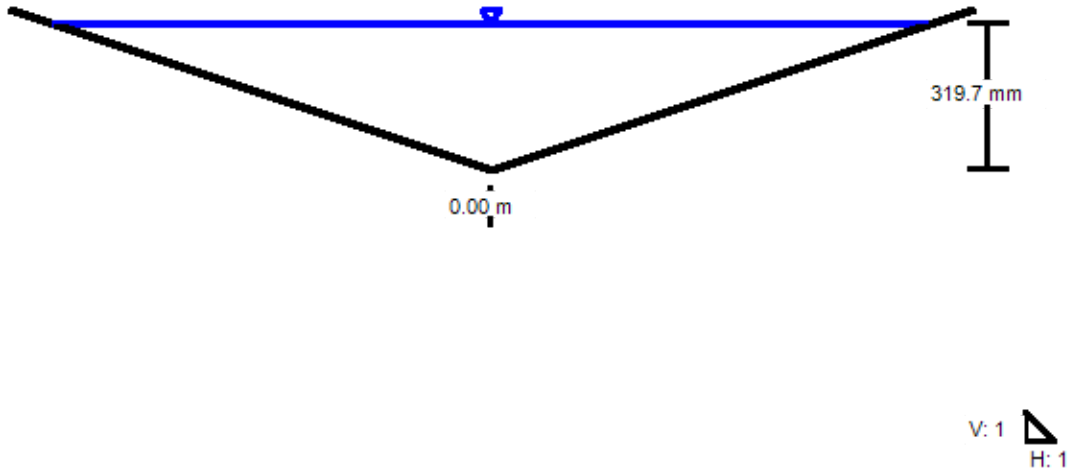

Stormceptor® EF Sizing Report

**STORMCEPTOR®
ESTIMATED NET ANNUAL SEDIMENT (TSS) LOAD REDUCTION**

12/22/2021

Province:	Ontario
City:	Wellington County
Nearest Rainfall Station:	WATERLOO WELLINGTON AP
Climate Station Id:	6149387
Years of Rainfall Data:	34

Project Name:	Ospringle Subdivision
Project Number:	111618
Designer Name:	Andy Kroess
Designer Company:	IBI Group
Designer Email:	andy.kroess@ibigroup.com
Designer Phone:	519-585-2255
EOR Name:	
EOR Company:	
EOR Email:	
EOR Phone:	

Site Name:	Ospringle Subdivision
------------	-----------------------

Drainage Area (ha):	2.903
% Imperviousness:	36.80

Runoff Coefficient 'c': 0.52

Particle Size Distribution:	Fine
Target TSS Removal (%):	80.0

Required Water Quality Runoff Volume Capture (%):	90.00
Estimated Water Quality Flow Rate (L/s):	60.19
Oil / Fuel Spill Risk Site?	Yes
Upstream Flow Control?	Yes
Upstream Orifice Control Flow Rate to Stormceptor (L/s):	90.00
Peak Conveyance (maximum) Flow Rate (L/s):	
Site Sediment Transport Rate (kg/ha/yr):	

Net Annual Sediment (TSS) Load Reduction Sizing Summary	
Stormceptor Model	TSS Removal Provided (%)
EFO4	54
EFO6	69
EFO8	78
EFO10	84
EFO12	90

Recommended Stormceptor EFO Model: EFO10
Estimated Net Annual Sediment (TSS) Load Reduction (%): 84
Water Quality Runoff Volume Capture (%): > 90

Stormceptor® EF Sizing Report

THIRD-PARTY TESTING AND VERIFICATION

► **Stormceptor® EF and Stormceptor® EFO** are the latest evolutions in the Stormceptor® oil-grit separator (OGS) technology series, and are designed to remove a wide variety of pollutants from stormwater and snowmelt runoff. These technologies have been third-party tested in accordance with the Canadian ETV **Procedure for Laboratory Testing of Oil-Grit Separators** and performance has been third-party verified in accordance with the **ISO 14034 Environmental Technology Verification (ETV)** protocol.

PERFORMANCE

► **Stormceptor® EF and EFO** remove stormwater pollutants through gravity separation and floatation, and feature a patent-pending design that generates positive removal of total suspended solids (TSS) throughout each storm event, including high-intensity storms. Captured pollutants include sediment, free oils, and sediment-bound pollutants such as nutrients, heavy metals, and petroleum hydrocarbons. Stormceptor is sized to remove a high level of TSS from the frequent rainfall events that contribute the vast majority of annual runoff volume and pollutant load. The technology incorporates an internal bypass to convey excessive stormwater flows from high-intensity storms through the device without resuspension and washout (scour) of previously captured pollutants. Proper routine maintenance ensures high pollutant removal performance and protection of downstream waterways.

PARTICLE SIZE DISTRIBUTION (PSD)

► The **Canadian ETV PSD** shown in the table below was used, or in part, for this sizing. This is the identical PSD that is referenced in the Canadian ETV **Procedure for Laboratory Testing of Oil-Grit Separators** for both sediment removal testing and scour testing. The Canadian ETV PSD contains a wide range of particle sizes in the sand and silt fractions, and is considered reasonably representative of the particle size fractions found in typical urban stormwater runoff.

Particle Size (µm)	Percent Less Than	Particle Size Fraction (µm)	Percent
1000	100	500-1000	5
500	95	250-500	5
250	90	150-250	15
150	75	100-150	15
100	60	75-100	10
75	50	50-75	5
50	45	20-50	10
20	35	8-20	15
8	20	5-8	10
5	10	2-5	5
2	5	<2	5

Stormceptor®EF Sizing Report

Upstream Flow Controlled Results

Rainfall Intensity (mm / hr)	Percent Rainfall Volume (%)	Cumulative Rainfall Volume (%)	Flow Rate (L/s)	Flow Rate (L/min)	Surface Loading Rate (L/min/m ²)	Removal Efficiency (%)	Incremental Removal (%)	Cumulative Removal (%)
1	20.0	20.0	4.20	252.0	35.0	100	20.0	20.0
2	15.8	35.8	8.41	504.0	69.0	94	14.8	34.8
3	11.2	47.0	12.61	757.0	104.0	89	9.9	44.7
4	8.7	55.7	16.81	1009.0	138.0	85	7.5	52.2
5	7.6	63.3	21.02	1261.0	173.0	81	6.1	58.3
6	6.4	69.7	25.22	1513.0	207.0	77	5.0	63.3
7	4.1	73.8	29.42	1765.0	242.0	75	3.1	66.4
8	2.8	76.7	33.62	2017.0	276.0	74	2.1	68.5
9	2.7	79.4	37.83	2270.0	311.0	72	2.0	70.5
10	2.4	81.7	42.03	2522.0	345.0	71	1.7	72.1
11	2.7	84.5	46.23	2774.0	380.0	69	1.9	74.0
12	2.2	86.7	50.44	3026.0	415.0	68	1.5	75.5
13	1.8	88.4	54.64	3278.0	449.0	66	1.2	76.7
14	1.0	89.5	58.84	3531.0	484.0	65	0.7	77.4
15	1.7	91.2	63.05	3783.0	518.0	64	1.1	78.5
16	1.2	92.3	67.25	4035.0	553.0	62	0.7	79.2
17	1.1	93.5	71.45	4287.0	587.0	61	0.7	79.9
18	0.6	94.1	75.65	4539.0	622.0	60	0.4	80.3
19	0.3	94.3	79.86	4791.0	656.0	60	0.2	80.4
20	0.7	95.0	84.06	5044.0	691.0	59	0.4	80.8
21	5.0	100.0	88.26	5296.0	725.0	59	2.9	83.8
22	0.0	100.0	90.00	5400.0	740.0	59	0.0	83.8
23	0.0	100.0	90.00	5400.0	740.0	59	0.0	83.8
24	0.0	100.0	90.00	5400.0	740.0	59	0.0	83.8
25	0.0	100.0	90.00	5400.0	740.0	59	0.0	83.8
30	0.0	100.0	90.00	5400.0	740.0	59	0.0	83.8
35	0.0	100.0	90.00	5400.0	740.0	59	0.0	83.8
40	0.0	100.0	90.00	5400.0	740.0	59	0.0	83.8
45	0.0	100.0	90.00	5400.0	740.0	59	0.0	83.8
50	0.0	100.0	90.00	5400.0	740.0	59	0.0	83.8
Estimated Net Annual Sediment (TSS) Load Reduction =								84 %

Climate Station ID: 6149387 Years of Rainfall Data: 34



Stormceptor® EF Sizing Report

RAINFALL DATA FROM WATERLOO WELLINGTON AP RAINFALL STATION

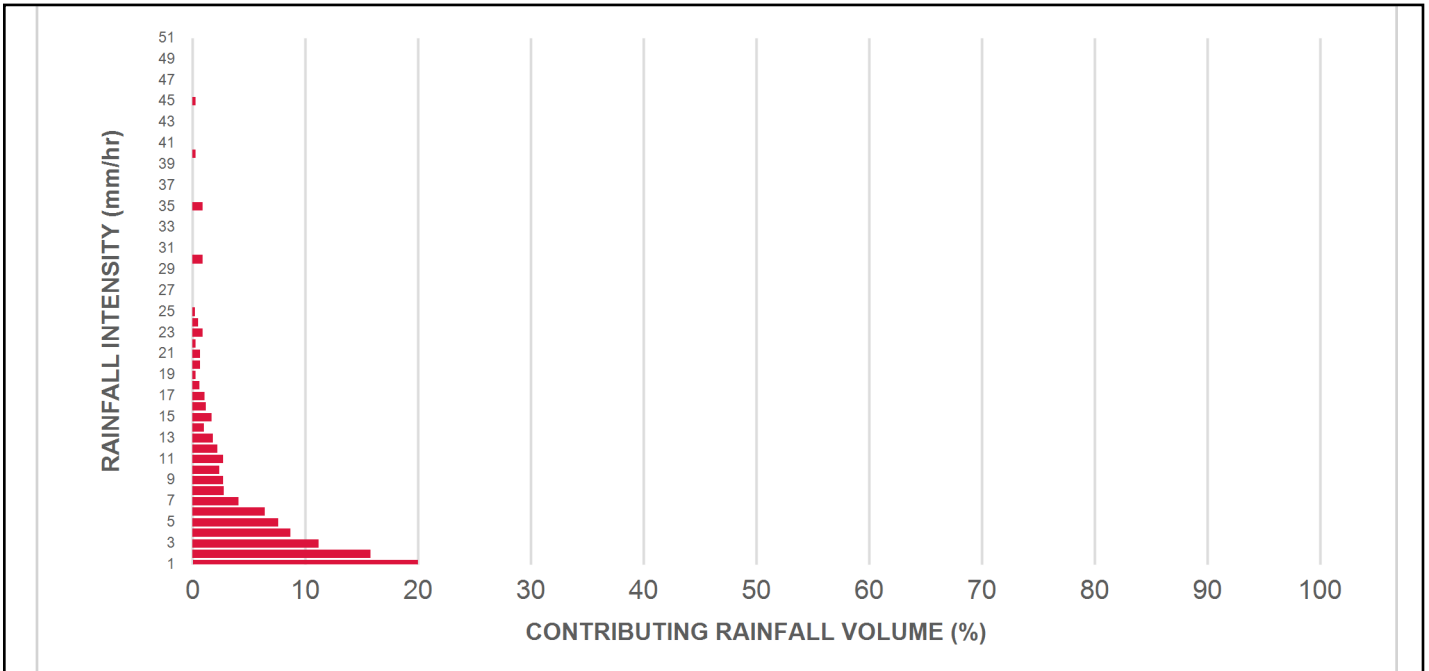

INCREMENTAL AND CUMULATIVE TSS REMOVAL FOR THE RECOMMENDED STORMCEPTOR® MODEL

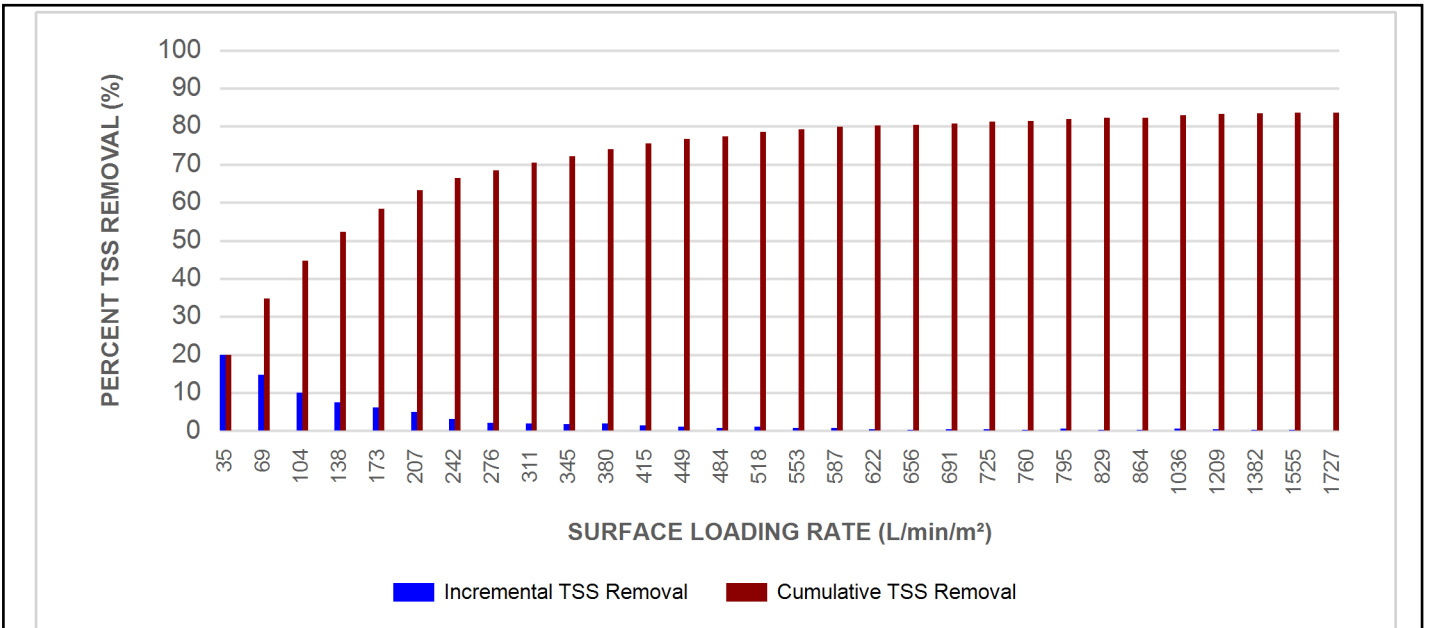

Stormceptor® **EF** Sizing Report

Maximum Pipe Diameter / Peak Conveyance

Stormceptor EF / EFO	Model Diameter		Min Angle Inlet / Outlet Pipes	Max Inlet Pipe Diameter		Max Outlet Pipe Diameter		Peak Conveyance Flow Rate	
	(m)	(ft)		(mm)	(in)	(mm)	(in)	(L/s)	(cfs)
EF4 / EFO4	1.2	4	90	609	24	609	24	425	15
EF6 / EFO6	1.8	6	90	914	36	914	36	990	35
EF8 / EFO8	2.4	8	90	1219	48	1219	48	1700	60
EF10 / EFO10	3.0	10	90	1828	72	1828	72	2830	100
EF12 / EFO12	3.6	12	90	1828	72	1828	72	2830	100

SCOUR PREVENTION AND ONLINE CONFIGURATION

► Stormceptor® EF and EFO feature an internal bypass and superior scour prevention technology that have been demonstrated in third-party testing according to the scour testing provisions of the Canadian ETV **Procedure for Laboratory Testing of Oil-Grit Separators**, and the exceptional scour test performance has been third-party verified in accordance with the ISO 14034 ETV protocol. As a result, Stormceptor EF and EFO are approved for online installation, eliminating the need for costly additional bypass structures, piping, and installation expense.

DESIGN FLEXIBILITY

► Stormceptor® EF and EFO offers design flexibility in one simplified platform, accepting stormwater flow from a single inlet pipe or multiple inlet pipes, and/or surface runoff through an inlet grate. The device can also serve as a junction structure, accommodate a 90-degree inlet-to-outlet bend angle, and can be modified to ensure performance in submerged conditions.

OIL CAPTURE AND RETENTION

► While Stormceptor® EF will capture and retain oil from dry weather spills and low intensity runoff, Stormceptor® EFO has demonstrated superior oil capture and greater than 99% oil retention in third-party testing according to the light liquid re-entrainment testing provisions of the Canadian ETV **Procedure for Laboratory Testing of Oil-Grit Separators**. Stormceptor EFO is recommended for sites where oil capture and retention is a requirement.

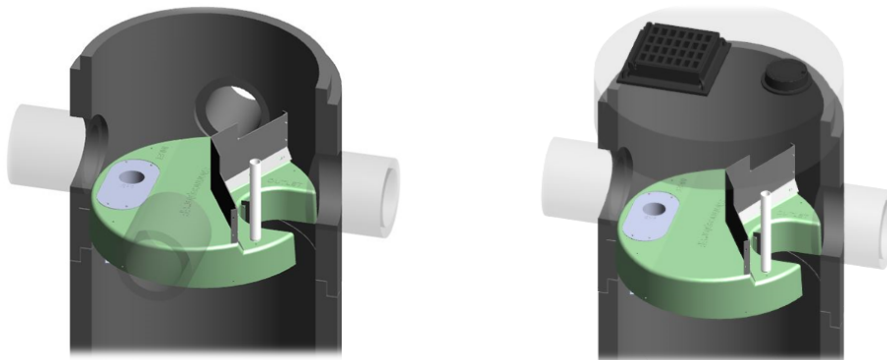

Stormceptor® EF Sizing Report

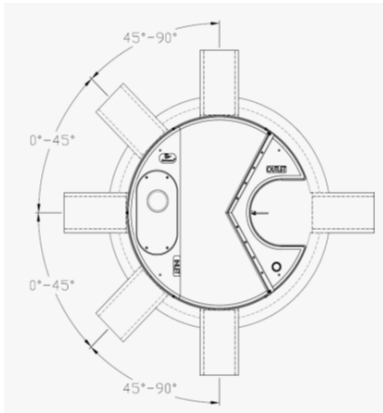

INLET-TO-OUTLET DROP

Elevation differential between inlet and outlet pipe inverts is dictated by the angle at which the inlet pipe(s) enters the unit.

0° - 45° : The inlet pipe is 1-inch (25mm) higher than the outlet pipe.

45° - 90° : The inlet pipe is 2-inches (50mm) higher than the outlet pipe.

HEAD LOSS

The head loss through Stormceptor EF is similar to that of a 60-degree bend structure. The applicable K value for calculating minor losses through the unit is 1.1.

For submerged conditions the applicable K value is 3.0.

Pollutant Capacity

Stormceptor EF / EFO	Model Diameter		Depth (Outlet Pipe Invert to Sump Floor)		Oil Volume		Recommended Sediment Maintenance Depth *		Maximum Sediment Volume *		Maximum Sediment Mass **	
	(m)	(ft)	(m)	(ft)	(L)	(Gal)	(mm)	(in)	(L)	(ft³)	(kg)	(lb)
EF4 / EFO4	1.2	4	1.52	5.0	265	70	203	8	1190	42	1904	5250
EF6 / EFO6	1.8	6	1.93	6.3	610	160	305	12	3470	123	5552	15375
EF8 / EFO8	2.4	8	2.59	8.5	1070	280	610	24	8780	310	14048	38750
EF10 / EFO10	3.0	10	3.25	10.7	1670	440	610	24	17790	628	28464	78500
EF12 / EFO12	3.6	12	3.89	12.8	2475	655	610	24	31220	1103	49952	137875

*Increased sump depth may be added to increase sediment storage capacity

** Average density of wet packed sediment in sump = 1.6 kg/L (100 lb/ft³)

Feature	Benefit	Feature Appeals To
Patent-pending enhanced flow treatment and scour prevention technology	Superior, verified third-party performance	Regulator, Specifying & Design Engineer
Third-party verified light liquid capture and retention for EFO version	Proven performance for fuel/oil hotspot locations	Regulator, Specifying & Design Engineer, Site Owner
Functions as bend, junction or inlet structure	Design flexibility	Specifying & Design Engineer
Minimal drop between inlet and outlet	Site installation ease	Contractor
Large diameter outlet riser for inspection and maintenance	Easy maintenance access from grade	Maintenance Contractor & Site Owner

STANDARD STORMCEPTOR EF/EFO DRAWINGS

For standard details, please visit <http://www.imbriumsystems.com/stormwater-treatment-solutions/stormceptor-ef>

STANDARD STORMCEPTOR EF/EFO SPECIFICATION

For specifications, please visit <http://www.imbriumsystems.com/stormwater-treatment-solutions/stormceptor-ef>

Stormceptor® **EF** Sizing Report

**STANDARD PERFORMANCE SPECIFICATION FOR
“OIL GRIT SEPARATOR” (OGS) STORMWATER QUALITY TREATMENT DEVICE**

PART 1 – GENERAL

1.1 WORK INCLUDED

This section specifies requirements for selecting, sizing, and designing an underground Oil Grit Separator (OGS) device for stormwater quality treatment, with third-party testing results and a Statement of Verification in accordance with ISO 14034 Environmental Management – Environmental Technology Verification (ETV).

1.2 REFERENCE STANDARDS & PROCEDURES

ISO 14034:2016 Environmental management – Environmental technology verification (ETV)

Canadian Environmental Technology Verification (ETV) Program’s **Procedure for Laboratory Testing of Oil-Grit Separators**

1.3 SUBMITTALS

1.3.1 All submittals, including sizing reports & shop drawings, shall be submitted upon request with each order to the contractor then forwarded to the Engineer of Record for review and acceptance. Shop drawings shall detail all OGS components, elevations, and sequence of construction.

1.3.2 Alternative devices shall have features identical to or greater than the specified device, including: treatment chamber diameter, treatment chamber wet volume, sediment storage volume, and oil storage volume.

1.3.3 Unless directed otherwise by the Engineer of Record, OGS stormwater quality treatment product substitutions or alternatives submitted within ten days prior to project bid shall not be accepted. All alternatives or substitutions submitted shall be signed and sealed by a local registered Professional Engineer, based on the exact same criteria detailed in Section 3, in entirety, subject to review and approval by the Engineer of Record.

PART 2 – PRODUCTS

2.1 OGS POLLUTANT STORAGE

The OGS device shall include a sump for sediment storage, and a protected volume for the capture and storage of petroleum hydrocarbons and buoyant gross pollutants. The minimum sediment & petroleum hydrocarbon storage capacity shall be as follows:

2.1.1	4 ft (1219 mm) Diameter OGS Units:	1.19 m ³ sediment / 265 L oil
	6 ft (1829 mm) Diameter OGS Units:	3.48 m ³ sediment / 609 L oil
	8 ft (2438 mm) Diameter OGS Units:	8.78 m ³ sediment / 1,071 L oil
	10 ft (3048 mm) Diameter OGS Units:	17.78 m ³ sediment / 1,673 L oil
	12 ft (3657 mm) Diameter OGS Units:	31.23 m ³ sediment / 2,476 L oil

PART 3 – PERFORMANCE & DESIGN

3.1 GENERAL

The OGS stormwater quality treatment device shall be verified in accordance with ISO 14034:2016 Environmental management – Environmental technology verification (ETV). The OGS stormwater quality treatment device shall



Stormceptor® EF Sizing Report

remove oil, sediment and gross pollutants from stormwater runoff during frequent wet weather events, and retain these pollutants during less frequent high flow wet weather events below the insert within the OGS for later removal during maintenance. The Manufacturer shall have at least ten (10) years of local experience, history and success in engineering design, manufacturing and production and supply of OGS stormwater quality treatment device systems, acceptable to the Engineer of Record.

3.2 SIZING METHODOLOGY

The OGS device shall be engineered, designed and sized to provide stormwater quality treatment based on treating a minimum of 90 percent of the average annual runoff volume and a minimum removal of an annual average 60% of the sediment (TSS) load based on the Particle Size Distribution (PSD) specified in the sizing report for the specified device. Sizing shall be determined using historical rainfall data and a sediment removal performance curve derived from the actual third-party verified laboratory testing data. The OGS device shall also have sufficient annual sediment storage capacity as specified and calculated in Section 2.1.

3.3 CANADIAN ETV or ISO 14034 ETV VERIFICATION OF SCOUR TESTING

The OGS device shall have Canadian ETV or ISO 14034 ETV Verification of third-party scour testing conducted in accordance with the Canadian ETV Program's **Procedure for Laboratory Testing of Oil-Grit Separators**.

3.3.1 To be acceptable for on-line installation, the OGS device must demonstrate an average scour test effluent concentration less than 10 mg/L at each surface loading rate tested, up to and including 2600 L/min/m².

3.4 LIGHT LIQUID RE-ENTRAINMENT SIMULATION TESTING

The OGS device shall have Canadian ETV or ISO 14034 ETV Verification of completed third-party Light Liquid Re-entrainment Simulation Testing in accordance with the Canadian ETV **Program's Procedure for Laboratory Testing of Oil-Grit Separators**, with results reported within the Canadian ETV or ISO 14034 ETV verification. This re-entrainment testing is conducted with the device pre-loaded with low density polyethylene (LDPE) plastic beads as a surrogate for light liquids such as oil and fuel. Testing is conducted on the same OGS unit tested for sediment removal to assess whether light liquids captured after a spill are effectively retained at high flow rates.

3.4.1 For an OGS device to be an acceptable stormwater treatment device on a site where vehicular traffic occurs and the potential for an oil or fuel spill exists, the OGS device must have reported verified performance results of greater than 99% cumulative retention of LDPE plastic beads for the five specified surface loading rates (ranging 200 L/min/m² to 2600 L/min/m²) in accordance with the Light Liquid Re-entrainment Simulation Testing within the Canadian ETV Program's **Procedure for Laboratory Testing of Oil-Grit Separators**. However, an OGS device shall not be allowed if the Light Liquid Re-entrainment Simulation Testing was performed with screening components within the OGS device that are effective at retaining the LDPE plastic beads, but would not be expected to retain light liquids such as oil and fuel.

Appendix B – Preliminary MIDUSS Model Output

Output File (4.7) 111618P3.OUT opened 2021-12-22 10:24

Units used are defined by G = 9.810

48 960 5.000 are MAXDT MAXHYD & DTMIN values

Licensee: PLANNING INITIATIVES LTD

35 COMMENT

6 line(s) of comment

 * 111618 - OSPRINGE DEVELOPMENT *
 * COUNTY OF WELLINGTON *
 * IBI GROUP *
 * JANUARY 2018 - REVISED DECEMBER 2021 *

35 COMMENT

4 line(s) of comment

 * 5 YEAR CHICAGO STORM *
 * FERGUS SHAND DAM IDF PARAMETERS *

2

STORM
 1 1=Chicago;2=Huff;3=User;4=Cdn1hr;5=Historic
 1428.056 Coefficient a
 11.305 Constant b (min)
 .851 Exponent c
 .400 Fraction to peak r
 180.000 Duration ó 240 min
 48.991 mm Total depth

3

IMPERVIOUS
 1 Option 1=SCS CN/C; 2=Horton; 3=Green-Ampt; 4=Repeat
 .013 Manning "n"
 98.000 SCS Curve No or C
 .100 Ia/S Coefficient
 .518 Initial Abstraction

35 COMMENT

3 line(s) of comment

 * EXISTING CONDITIONS *

35 COMMENT

3 line(s) of comment

 * AREA 104 *

4

CATCHMENT
 104.000 ID No.ó 99999
 .382 Area in hectares
 20.000 Length (PERV) metres
 4.000 Gradient (%)
 .000 Per cent Impervious
 20.000 Length (IMPERV)
 .000 %Imp. with Zero Dpth
 1 Option 1=SCS CN/C; 2=Horton; 3=Green-Ampt; 4=Repeat
 .250 Manning "n"
 71.000 SCS Curve No or C
 .100 Ia/S Coefficient
 10.375 Initial Abstraction
 1 Option 1=Trianglr; 2=Rectanglr; 3=SWM HYD; 4=Lin. Reserv
 .015 .000 .000 .000 c.m/s
 .213 .000 .213 C perv/imperv/total

35 COMMENT

3 line(s) of comment

 * PEAK FLOW TO WEST *

15 ADD RUNOFF

.015 .015 .000 .000 c.m/s

14 START

```

1      1=Zero; 2=Define
35     COMMENT
3      line(s) of comment
*****
* AREA 102 *
*****
4     CATCHMENT
102.000 ID No.6 99999
      .928 Area in hectares
30.000 Length (PERV) metres
4.000 Gradient (%)
      .000 Per cent Impervious
30.000 Length (IMPERV)
      .000 %Imp. with Zero Dpth
      1 Option 1=SCS CN/C; 2=Horton; 3=Green-Ampt; 4=Repeat
      .250 Manning "n"
71.000 SCS Curve No or C
      .100 Ia/S Coefficient
10.375 Initial Abstraction
      1 Option 1=Trianglr; 2=Rectanglr; 3=SWM HYD; 4=Lin. Reserv
      .032 .000 .000 .000 c.m/s
      .214 .000 .214 C perv/imperv/total
15     ADD RUNOFF
      .032 .032 .000 .000 c.m/s
9     ROUTE
      .000 Conduit Length
      .000 No Conduit defined
      .000 Zero lag
      .000 Beta weighting factor
      .000 Routing timestep
      0 No. of sub-reaches
      .032 .032 .032 .000 c.m/s
17     COMBINE
500 Junction Node No.
      .032 .032 .032 .032 c.m/s
14     START
1      1=Zero; 2=Define
35     COMMENT
3      line(s) of comment
*****
* AREA 103 *
*****
4     CATCHMENT
103.000 ID No.6 99999
      .069 Area in hectares
10.000 Length (PERV) metres
2.000 Gradient (%)
72.000 Per cent Impervious
10.000 Length (IMPERV)
      .000 %Imp. with Zero Dpth
      1 Option 1=SCS CN/C; 2=Horton; 3=Green-Ampt; 4=Repeat
      .250 Manning "n"
71.000 SCS Curve No or C
      .100 Ia/S Coefficient
10.375 Initial Abstraction
      1 Option 1=Trianglr; 2=Rectanglr; 3=SWM HYD; 4=Lin. Reserv
      .015 .000 .032 .032 c.m/s
      .213 .862 .680 C perv/imperv/total
15     ADD RUNOFF
      .015 .015 .032 .032 c.m/s
9     ROUTE
      .000 Conduit Length
      .000 No Conduit defined
      .000 Zero lag
      .000 Beta weighting factor
      .000 Routing timestep

```

```

0      No. of sub-reaches
      .015      .015      .015      .032 c.m/s
17  COMBINE
500   Junction Node No.
      .015      .015      .015      .036 c.m/s
18  CONFLUENCE
500   Junction Node No.
      .015      .036      .015      .000 c.m/s
35  COMMENT
3     line(s) of comment
*****
* AREA 107 *
*****
4  CATCHMENT
107.000 ID No.ó 99999
2.560   Area in hectares
50.000  Length (PERV) metres
4.000   Gradient (%)
1.000   Per cent Impervious
50.000  Length (IMPERV)
.000    %Imp. with Zero Dpth
1       Option 1=SCS CN/C; 2=Horton; 3=Green-Ampt; 4=Repeat
.250    Manning "n"
71.000  SCS Curve No or C
.100    Ia/S Coefficient
10.375  Initial Abstraction
1       Option 1=Trianglr; 2=Rectanglr; 3=SWM HYD; 4=Lin. Reserv
      .074      .036      .015      .000 c.m/s
      .214      .881      .220      C perv/imperv/total
15  ADD RUNOFF
      .074      .110      .015      .000 c.m/s
9   ROUTE
.000    Conduit Length
.000    No Conduit defined
.000    Zero lag
.000    Beta weighting factor
.000    Routing timestep
0       No. of sub-reaches
      .074      .110      .110      .000 c.m/s
17  COMBINE
600   Junction Node No.
      .074      .110      .110      .110 c.m/s
14  START
1     1=Zero; 2=Define
35  COMMENT
3     line(s) of comment
*****
* AREA 101 *
*****
4  CATCHMENT
101.000 ID No.ó 99999
.269    Area in hectares
20.000  Length (PERV) metres
2.000   Gradient (%)
4.000   Per cent Impervious
20.000  Length (IMPERV)
.000    %Imp. with Zero Dpth
1       Option 1=SCS CN/C; 2=Horton; 3=Green-Ampt; 4=Repeat
.250    Manning "n"
71.000  SCS Curve No or C
.100    Ia/S Coefficient
10.375  Initial Abstraction
1       Option 1=Trianglr; 2=Rectanglr; 3=SWM HYD; 4=Lin. Reserv
      .010      .000      .110      .110 c.m/s
      .214      .880      .240      C perv/imperv/total
15  ADD RUNOFF

```

```

      .010      .010      .110      .110 c.m/s
35  COMMENT
    3  line(s) of comment
    *****
    * AREA 105 *
    *****
4  CATCHMENT
105.000  ID No.6 99999
   .533  Area in hectares
20.000  Length (PERV) metres
  4.000  Gradient (%)
   .000  Per cent Impervious
20.000  Length (IMPERV)
   .000  %Imp. with Zero Dpth
     1  Option 1=SCS CN/C; 2=Horton; 3=Green-Ampt; 4=Repeat
   .250  Manning "n"
71.000  SCS Curve No or C
   .100  Ia/S Coefficient
10.375  Initial Abstraction
     1  Option 1=Trianglr; 2=Rectanglr; 3=SWM HYD; 4=Lin. Reserv
      .021      .010      .110      .110 c.m/s
      .213      .000      .213      C perv/imperv/total
15  ADD RUNOFF
      .021      .031      .110      .110 c.m/s
9  ROUTE
   .000  Conduit Length
   .000  No Conduit defined
   .000  Zero lag
   .000  Beta weighting factor
   .000  Routing timestep
     0  No. of sub-reaches
      .021      .031      .031      .110 c.m/s
17  COMBINE
600  Junction Node No.
      .021      .031      .031      .139 c.m/s
14  START
     1  1=Zero; 2=Define
35  COMMENT
    3  line(s) of comment
    *****
    * AREA 106 *
    *****
4  CATCHMENT
106.000  ID No.6 99999
   .147  Area in hectares
20.000  Length (PERV) metres
  4.000  Gradient (%)
   .000  Per cent Impervious
20.000  Length (IMPERV)
   .000  %Imp. with Zero Dpth
     1  Option 1=SCS CN/C; 2=Horton; 3=Green-Ampt; 4=Repeat
   .250  Manning "n"
71.000  SCS Curve No or C
   .100  Ia/S Coefficient
10.375  Initial Abstraction
     1  Option 1=Trianglr; 2=Rectanglr; 3=SWM HYD; 4=Lin. Reserv
      .006      .000      .031      .139 c.m/s
      .213      .000      .213      C perv/imperv/total
15  ADD RUNOFF
      .006      .006      .031      .139 c.m/s
9  ROUTE
   .000  Conduit Length
   .000  No Conduit defined
   .000  Zero lag
   .000  Beta weighting factor
   .000  Routing timestep

```

```

0      No. of sub-reaches
      .006      .006      .006      .139 c.m/s
17  COMBINE
600  Junction Node No.
      .006      .006      .006      .144 c.m/s
35  COMMENT
3    line(s) of comment
*****
* PEAK FLOW TO EAST *
*****
18  CONFLUENCE
600  Junction Node No.
      .006      .144      .006      .000 c.m/s
14  START
1    1=Zero; 2=Define
35  COMMENT
3    line(s) of comment
*****
* PROPOSED CONDITIONS *
*****
35  COMMENT
3    line(s) of comment
*****
* AREA 202 *
*****
4    CATCHMENT
202.000  ID No.6 99999
      .337  Area in hectares
20.000  Length (PERV) metres
4.000  Gradient (%)
.000  Per cent Impervious
20.000  Length (IMPERV)
.000  %Imp. with Zero Dpth
1  Option 1=SCS CN/C; 2=Horton; 3=Green-Ampt; 4=Repeat
.250  Manning "n"
71.000  SCS Curve No or C
.100  Ia/S Coefficient
10.375  Initial Abstraction
1  Option 1=Trianglr; 2=Rectanglr; 3=SWM HYD; 4=Lin. Reserv
      .013      .000      .006      .000 c.m/s
      .213      .000      .213      C perv/imperv/total
35  COMMENT
3    line(s) of comment
*****
* PEAK FLOW TO WEST *
*****
15  ADD RUNOFF
      .013      .013      .006      .000 c.m/s
14  START
1    1=Zero; 2=Define
35  COMMENT
3    line(s) of comment
*****
* AREA 102 *
*****
4    CATCHMENT
102.000  ID No.6 99999
      .928  Area in hectares
30.000  Length (PERV) metres
4.000  Gradient (%)
.000  Per cent Impervious
30.000  Length (IMPERV)
.000  %Imp. with Zero Dpth
1  Option 1=SCS CN/C; 2=Horton; 3=Green-Ampt; 4=Repeat
.250  Manning "n"
71.000  SCS Curve No or C

```

```

.100    Ia/S Coefficient
10.375  Initial Abstraction
      1  Option 1=Trianglr; 2=Rectanglr; 3=SWM HYD; 4=Lin. Reserv
      .032 .000 .006 .000 c.m/s
      .214 .000 .214 C perv/imperv/total
15  ADD RUNOFF
      .032 .032 .006 .000 c.m/s
35  COMMENT
      3  line(s) of comment
      *****
      * AREA 203 *
      *****
4  CATCHMENT
203.000 ID No.6 99999
      .648 Area in hectares
20.000 Length (PERV) metres
      4.000 Gradient (%)
      .000 Per cent Impervious
20.000 Length (IMPERV)
      .000 %Imp. with Zero Dpth
      1  Option 1=SCS CN/C; 2=Horton; 3=Green-Ampt; 4=Repeat
      .250 Manning "n"
71.000 SCS Curve No or C
      .100 Ia/S Coefficient
10.375 Initial Abstraction
      1  Option 1=Trianglr; 2=Rectanglr; 3=SWM HYD; 4=Lin. Reserv
      .026 .032 .006 .000 c.m/s
      .213 .000 .213 C perv/imperv/total
15  ADD RUNOFF
      .026 .057 .006 .000 c.m/s
35  COMMENT
      3  line(s) of comment
      *****
      * AREA 103 *
      *****
4  CATCHMENT
103.000 ID No.6 99999
      .069 Area in hectares
10.000 Length (PERV) metres
      2.000 Gradient (%)
72.000 Per cent Impervious
10.000 Length (IMPERV)
      .000 %Imp. with Zero Dpth
      1  Option 1=SCS CN/C; 2=Horton; 3=Green-Ampt; 4=Repeat
      .250 Manning "n"
71.000 SCS Curve No or C
      .100 Ia/S Coefficient
10.375 Initial Abstraction
      1  Option 1=Trianglr; 2=Rectanglr; 3=SWM HYD; 4=Lin. Reserv
      .015 .057 .006 .000 c.m/s
      .213 .862 .680 C perv/imperv/total
15  ADD RUNOFF
      .015 .062 .006 .000 c.m/s
9  ROUTE
      .000 Conduit Length
      .000 No Conduit defined
      .000 Zero lag
      .000 Beta weighting factor
      .000 Routing timestep
      0  No. of sub-reaches
      .015 .062 .062 .000 c.m/s
17  COMBINE
700  Junction Node No.
      .015 .062 .062 .062 c.m/s
14  START
      1  1=Zero; 2=Define

```

```

35  COMMENT
    3  line(s) of comment
    *****
    * AREA 201 *
    *****
4  CATCHMENT
201.000  ID No.ó 99999
    2.110  Area in hectares
    20.000  Length (PERV) metres
    4.000  Gradient (%)
    50.000  Per cent Impervious
    20.000  Length (IMPERV)
    .000  %Imp. with Zero Dpth
    1  Option 1=SCS CN/C; 2=Horton; 3=Green-Ampt; 4=Repeat
    .250  Manning "n"
    71.000  SCS Curve No or C
    .100  Ia/S Coefficient
    10.375  Initial Abstraction
    1  Option 1=Trianglr; 2=Rectanglr; 3=SWM HYD; 4=Lin. Reserv
    .329  .000  .062  .062 c.m/s
    .213  .873  .543  C perv/imperv/total
15  ADD RUNOFF
    .329  .329  .062  .062 c.m/s
35  COMMENT
    3  line(s) of comment
    *****
    * AREA 204 *
    *****
4  CATCHMENT
204.000  ID No.ó 99999
    .145  Area in hectares
    10.000  Length (PERV) metres
    2.000  Gradient (%)
    10.000  Per cent Impervious
    10.000  Length (IMPERV)
    .000  %Imp. with Zero Dpth
    1  Option 1=SCS CN/C; 2=Horton; 3=Green-Ampt; 4=Repeat
    .250  Manning "n"
    71.000  SCS Curve No or C
    .100  Ia/S Coefficient
    10.375  Initial Abstraction
    1  Option 1=Trianglr; 2=Rectanglr; 3=SWM HYD; 4=Lin. Reserv
    .007  .329  .062  .062 c.m/s
    .213  .862  .278  C perv/imperv/total
15  ADD RUNOFF
    .007  .335  .062  .062 c.m/s
35  COMMENT
    3  line(s) of comment
    *****
    * UNDERGROUND STORAGE *
    *****
10  POND
    11 Depth - Discharge - Volume sets
    .000  .000  .0
    .100  .0295  65.0
    .200  .0313  130.9
    .300  .0458  195.0
    .400  .0567  260.0
    .500  .0658  325.0
    .600  .0738  390.0
    .700  .0809  455.0
    .800  .0876  520.0
    .900  .195  585.0
    1.000  .386  650.0
    Peak Outflow  =  .063 c.m/s
    Maximum Depth  =  .474 metres

```

```

Maximum Storage =      308. c.m
                .007      .335      .063      .062 c.m/s
17  COMBINE
700  Junction Node No.
     .007      .335      .063      .121 c.m/s
14  START
1    1=Zero; 2=Define
35  COMMENT
3    line(s) of comment
     *****
     * AREA 101 *
     *****
4    CATCHMENT
101.000 ID No.6 99999
     .269 Area in hectares
20.000 Length (PERV) metres
2.000 Gradient (%)
4.000 Per cent Impervious
20.000 Length (IMPERV)
     .000 %Imp. with Zero Dpth
     1 Option 1=SCS CN/C; 2=Horton; 3=Green-Ampt; 4=Repeat
     .250 Manning "n"
71.000 SCS Curve No or C
     .100 Ia/S Coefficient
10.375 Initial Abstraction
     1 Option 1=Trianglr; 2=Rectanglr; 3=SWM HYD; 4=Lin. Reserv
     .010      .000      .063      .121 c.m/s
     .214      .880      .240      C perv/imperv/total
15  ADD RUNOFF
     .010      .010      .063      .121 c.m/s
35  COMMENT
3    line(s) of comment
     *****
     * AREA 205 *
     *****
4    CATCHMENT
205.000 ID No.6 99999
     .368 Area in hectares
10.000 Length (PERV) metres
10.000 Gradient (%)
     .000 Per cent Impervious
10.000 Length (IMPERV)
     .000 %Imp. with Zero Dpth
     1 Option 1=SCS CN/C; 2=Horton; 3=Green-Ampt; 4=Repeat
     .250 Manning "n"
71.000 SCS Curve No or C
     .100 Ia/S Coefficient
10.375 Initial Abstraction
     1 Option 1=Trianglr; 2=Rectanglr; 3=SWM HYD; 4=Lin. Reserv
     .019      .010      .063      .121 c.m/s
     .212      .000      .212      C perv/imperv/total
15  ADD RUNOFF
     .019      .028      .063      .121 c.m/s
9    ROUTE
     .000 Conduit Length
     .000 No Conduit defined
     .000 Zero lag
     .000 Beta weighting factor
     .000 Routing timestep
     0 No. of sub-reaches
     .019      .028      .028      .121 c.m/s
17  COMBINE
700  Junction Node No.
     .019      .028      .028      .144 c.m/s
35  COMMENT
3    line(s) of comment

```

```

*****
* PEAK FLOW TO EAST *
*****
18 CONFLUENCE
700 Junction Node No.
      .019      .144      .028      .000 c.m/s
14 START
1     1=Zero; 2=Define
35 COMMENT
4     line(s) of comment
*****
* 10 YEAR CHICAGO STORM *
* FERGUS SHAND DAM IDF PARAMETERS *
*****
2     STORM
      1     1=Chicago;2=Huff;3=User;4=Cdn1hr;5=Historic
2116.523 Coefficient a
14.709 Constant b (min)
      .884 Exponent c
      .400 Fraction to peak r
180.000 Duration ó 240 min
      60.107 mm Total depth
3     IMPERVIOUS
      1     Option 1=SCS CN/C; 2=Horton; 3=Green-Ampt; 4=Repeat
      .013 Manning "n"
98.000 SCS Curve No or C
      .100 Ia/S Coefficient
      .518 Initial Abstraction
35 COMMENT
3     line(s) of comment
*****
* EXISTING CONDITIONS *
*****
35 COMMENT
3     line(s) of comment
*****
* AREA 104 *
*****
4     CATCHMENT
104.000 ID No.ó 99999
      .382 Area in hectares
20.000 Length (PERV) metres
4.000 Gradient (%)
      .000 Per cent Impervious
20.000 Length (IMPERV)
      .000 %Imp. with Zero Dpth
      1     Option 1=SCS CN/C; 2=Horton; 3=Green-Ampt; 4=Repeat
      .250 Manning "n"
71.000 SCS Curve No or C
      .100 Ia/S Coefficient
10.375 Initial Abstraction
      1     Option 1=Trianglr; 2=Rectanglr; 3=SWM HYD; 4=Lin. Reserv
      .025      .000      .028      .000 c.m/s
      .268      .000      .268      C perv/imperv/total
35 COMMENT
3     line(s) of comment
*****
* PEAK FLOW TO WEST *
*****
15 ADD RUNOFF
      .025      .025      .028      .000 c.m/s
14 START
1     1=Zero; 2=Define
35 COMMENT
3     line(s) of comment
*****

```

```

* AREA 102 *
*****
4  CATCHMENT
102.000  ID No.6 99999
.928    Area in hectares
30.000  Length (PERV) metres
4.000   Gradient (%)
.000    Per cent Impervious
30.000  Length (IMPERV)
.000    %Imp. with Zero Dpth
1       Option 1=SCS CN/C; 2=Horton; 3=Green-Ampt; 4=Repeat
.250    Manning "n"
71.000  SCS Curve No or C
.100    Ia/S Coefficient
10.375  Initial Abstraction
1       Option 1=Trianglr; 2=Rectanglr; 3=SWM HYD; 4=Lin. Reserv
.058    .000    .028    .000 c.m/s
.268    .000    .268    C perv/imperv/total
15  ADD RUNOFF
.058    .058    .028    .000 c.m/s
9   ROUTE
.000    Conduit Length
.000    No Conduit defined
.000    Zero lag
.000    Beta weighting factor
.000    Routing timestep
0       No. of sub-reaches
.058    .058    .058    .000 c.m/s
17  COMBINE
500    Junction Node No.
.058    .058    .058    .058 c.m/s
14  START
1       1=Zero; 2=Define
35  COMMENT
3       line(s) of comment
*****
* AREA 103 *
*****
4  CATCHMENT
103.000  ID No.6 99999
.069    Area in hectares
10.000  Length (PERV) metres
2.000   Gradient (%)
72.000  Per cent Impervious
10.000  Length (IMPERV)
.000    %Imp. with Zero Dpth
1       Option 1=SCS CN/C; 2=Horton; 3=Green-Ampt; 4=Repeat
.250    Manning "n"
71.000  SCS Curve No or C
.100    Ia/S Coefficient
10.375  Initial Abstraction
1       Option 1=Trianglr; 2=Rectanglr; 3=SWM HYD; 4=Lin. Reserv
.018    .000    .058    .058 c.m/s
.266    .876    .705    C perv/imperv/total
15  ADD RUNOFF
.018    .018    .058    .058 c.m/s
9   ROUTE
.000    Conduit Length
.000    No Conduit defined
.000    Zero lag
.000    Beta weighting factor
.000    Routing timestep
0       No. of sub-reaches
.018    .018    .018    .058 c.m/s
17  COMBINE
500    Junction Node No.

```

```

111618P3.OUT
      .018      .018      .018      .064 c.m/s
18  CONFLUENCE
500  Junction Node No.
      .018      .064      .018      .000 c.m/s
35  COMMENT
3    line(s) of comment
*****
* AREA 107 *
*****
4    CATCHMENT
107.000 ID No.ó 99999
2.560   Area in hectares
50.000  Length (PERV) metres
4.000   Gradient (%)
1.000   Per cent Impervious
50.000  Length (IMPERV)
.000    %Imp. with Zero Dpth
1       Option 1=SCS CN/C; 2=Horton; 3=Green-Ampt; 4=Repeat
.250    Manning "n"
71.000  SCS Curve No or C
.100    Ia/S Coefficient
10.375  Initial Abstraction
1       Option 1=Trianglr; 2=Rectanglr; 3=SWM HYD; 4=Lin. Reserv
      .131      .064      .018      .000 c.m/s
      .268      .899      .274      C perv/imperv/total
15  ADD RUNOFF
      .131      .189      .018      .000 c.m/s
9    ROUTE
      .000      Conduit Length
      .000      No Conduit defined
      .000      Zero lag
      .000      Beta weighting factor
      .000      Routing timestep
      0       No. of sub-reaches
      .131      .189      .189      .000 c.m/s
17  COMBINE
600  Junction Node No.
      .131      .189      .189      .189 c.m/s
14  START
1    1=Zero; 2=Define
35  COMMENT
3    line(s) of comment
*****
* AREA 101 *
*****
4    CATCHMENT
101.000 ID No.ó 99999
.269    Area in hectares
20.000  Length (PERV) metres
2.000   Gradient (%)
4.000   Per cent Impervious
20.000  Length (IMPERV)
.000    %Imp. with Zero Dpth
1       Option 1=SCS CN/C; 2=Horton; 3=Green-Ampt; 4=Repeat
.250    Manning "n"
71.000  SCS Curve No or C
.100    Ia/S Coefficient
10.375  Initial Abstraction
1       Option 1=Trianglr; 2=Rectanglr; 3=SWM HYD; 4=Lin. Reserv
      .017      .000      .189      .189 c.m/s
      .268      .897      .293      C perv/imperv/total
15  ADD RUNOFF
      .017      .017      .189      .189 c.m/s
35  COMMENT
3    line(s) of comment
*****

```

```

* AREA 105 *
*****
4  CATCHMENT
105.000  ID No.6 99999
.533    Area in hectares
20.000  Length (PERV) metres
4.000   Gradient (%)
.000    Per cent Impervious
20.000  Length (IMPERV)
.000    %Imp. with Zero Dpth
1       Option 1=SCS CN/C; 2=Horton; 3=Green-Ampt; 4=Repeat
.250    Manning "n"
71.000  SCS Curve No or C
.100    Ia/S Coefficient
10.375  Initial Abstraction
1       Option 1=Trianglr; 2=Rectanglr; 3=SWM HYD; 4=Lin. Reserv
.035    .017    .189    .189 c.m/s
.268    .000    .268    C perv/imperv/total
15  ADD RUNOFF
.035    .052    .189    .189 c.m/s
9  ROUTE
.000    Conduit Length
.000    No Conduit defined
.000    Zero lag
.000    Beta weighting factor
.000    Routing timestep
0       No. of sub-reaches
.035    .052    .052    .189 c.m/s
17  COMBINE
600    Junction Node No.
.035    .052    .052    .241 c.m/s
14  START
1       1=Zero; 2=Define
35  COMMENT
3       line(s) of comment
*****
* AREA 106 *
*****
4  CATCHMENT
106.000  ID No.6 99999
.147    Area in hectares
20.000  Length (PERV) metres
4.000   Gradient (%)
.000    Per cent Impervious
20.000  Length (IMPERV)
.000    %Imp. with Zero Dpth
1       Option 1=SCS CN/C; 2=Horton; 3=Green-Ampt; 4=Repeat
.250    Manning "n"
71.000  SCS Curve No or C
.100    Ia/S Coefficient
10.375  Initial Abstraction
1       Option 1=Trianglr; 2=Rectanglr; 3=SWM HYD; 4=Lin. Reserv
.010    .000    .052    .241 c.m/s
.268    .000    .268    C perv/imperv/total
15  ADD RUNOFF
.010    .010    .052    .241 c.m/s
9  ROUTE
.000    Conduit Length
.000    No Conduit defined
.000    Zero lag
.000    Beta weighting factor
.000    Routing timestep
0       No. of sub-reaches
.010    .010    .010    .241 c.m/s
17  COMBINE
600    Junction Node No.

```

```

      .010      .010      .010      .251 c.m/s
35  COMMENT
      3      line(s) of comment
      *****
      * PEAK FLOW TO EAST *
      *****
18  CONFLUENCE
600  Junction Node No.
      .010      .251      .010      .000 c.m/s
14  START
      1      1=Zero; 2=Define
35  COMMENT
      3      line(s) of comment
      *****
      * PROPOSED CONDITIONS *
      *****
35  COMMENT
      3      line(s) of comment
      *****
      * AREA 202 *
      *****
4   CATCHMENT
202.000  ID No.6 99999
      .337  Area in hectares
20.000  Length (PERV) metres
4.000  Gradient (%)
      .000  Per cent Impervious
20.000  Length (IMPERV)
      .000  %Imp. with Zero Dpth
      1      Option 1=SCS CN/C; 2=Horton; 3=Green-Ampt; 4=Repeat
      .250  Manning "n"
71.000  SCS Curve No or C
      .100  Ia/S Coefficient
10.375  Initial Abstraction
      1      Option 1=Trianglr; 2=Rectanglr; 3=SWM HYD; 4=Lin. Reserv
      .022      .000      .010      .000 c.m/s
      .268      .000      .268      C perv/imperv/total
35  COMMENT
      3      line(s) of comment
      *****
      * PEAK FLOW TO WEST *
      *****
15  ADD RUNOFF
      .022      .022      .010      .000 c.m/s
14  START
      1      1=Zero; 2=Define
35  COMMENT
      3      line(s) of comment
      *****
      * AREA 102 *
      *****
4   CATCHMENT
102.000  ID No.6 99999
      .928  Area in hectares
30.000  Length (PERV) metres
4.000  Gradient (%)
      .000  Per cent Impervious
30.000  Length (IMPERV)
      .000  %Imp. with Zero Dpth
      1      Option 1=SCS CN/C; 2=Horton; 3=Green-Ampt; 4=Repeat
      .250  Manning "n"
71.000  SCS Curve No or C
      .100  Ia/S Coefficient
10.375  Initial Abstraction
      1      Option 1=Trianglr; 2=Rectanglr; 3=SWM HYD; 4=Lin. Reserv
      .058      .000      .010      .000 c.m/s

```

```

      .268      .000      .268      C perv/imperv/total
15  ADD RUNOFF
      .058      .058      .010      .000 c.m/s
35  COMMENT
3    line(s) of comment
*****
* AREA 203 *
*****
4    CATCHMENT
203.000  ID No.6 99999
      .648  Area in hectares
20.000  Length (PERV) metres
4.000  Gradient (%)
      .000  Per cent Impervious
20.000  Length (IMPERV)
      .000  %Imp. with Zero Dpth
      1    Option 1=SCS CN/C; 2=Horton; 3=Green-Ampt; 4=Repeat
      .250  Manning "n"
71.000  SCS Curve No or C
      .100  Ia/S Coefficient
10.375  Initial Abstraction
      1    Option 1=Trianglr; 2=Rectanglr; 3=SWM HYD; 4=Lin. Reserv
      .042      .058      .010      .000 c.m/s
      .268      .000      .268      C perv/imperv/total
15  ADD RUNOFF
      .042      .100      .010      .000 c.m/s
35  COMMENT
3    line(s) of comment
*****
* AREA 103 *
*****
4    CATCHMENT
103.000  ID No.6 99999
      .069  Area in hectares
10.000  Length (PERV) metres
2.000  Gradient (%)
72.000  Per cent Impervious
10.000  Length (IMPERV)
      .000  %Imp. with Zero Dpth
      1    Option 1=SCS CN/C; 2=Horton; 3=Green-Ampt; 4=Repeat
      .250  Manning "n"
71.000  SCS Curve No or C
      .100  Ia/S Coefficient
10.375  Initial Abstraction
      1    Option 1=Trianglr; 2=Rectanglr; 3=SWM HYD; 4=Lin. Reserv
      .018      .100      .010      .000 c.m/s
      .266      .876      .705      C perv/imperv/total
15  ADD RUNOFF
      .018      .106      .010      .000 c.m/s
9    ROUTE
      .000  Conduit Length
      .000  No Conduit defined
      .000  Zero lag
      .000  Beta weighting factor
      .000  Routing timestep
      0    No. of sub-reaches
      .018      .106      .106      .000 c.m/s
17  COMBINE
700  Junction Node No.
      .018      .106      .106      .106 c.m/s
14  START
1    1=Zero; 2=Define
35  COMMENT
3    line(s) of comment
*****
* AREA 201 *

```

```

*****
4  CATCHMENT
201.000  ID No.ó 99999
2.110   Area in hectares
20.000  Length (PERV) metres
4.000   Gradient (%)
50.000  Per cent Impervious
20.000  Length (IMPERV)
.000    %Imp. with Zero Dpth
1       Option 1=SCS CN/C; 2=Horton; 3=Green-Ampt; 4=Repeat
.250    Manning "n"
71.000  SCS Curve No or C
.100    Ia/S Coefficient
10.375  Initial Abstraction
1       Option 1=Trianglr; 2=Rectanglr; 3=SWM HYD; 4=Lin. Reserv
        .393      .000      .106      .106 c.m/s
        .268      .889      .578      C perv/imperv/total
15  ADD RUNOFF
        .393      .393      .106      .106 c.m/s
35  COMMENT
3     line(s) of comment
*****
* AREA 204 *
*****
4  CATCHMENT
204.000  ID No.ó 99999
.145    Area in hectares
10.000  Length (PERV) metres
2.000   Gradient (%)
10.000  Per cent Impervious
10.000  Length (IMPERV)
.000    %Imp. with Zero Dpth
1       Option 1=SCS CN/C; 2=Horton; 3=Green-Ampt; 4=Repeat
.250    Manning "n"
71.000  SCS Curve No or C
.100    Ia/S Coefficient
10.375  Initial Abstraction
1       Option 1=Trianglr; 2=Rectanglr; 3=SWM HYD; 4=Lin. Reserv
        .012      .393      .106      .106 c.m/s
        .266      .876      .327      C perv/imperv/total
15  ADD RUNOFF
        .012      .400      .106      .106 c.m/s
35  COMMENT
3     line(s) of comment
*****
* UNDERGROUND STORAGE *
*****
10  POND
11  Depth - Discharge - Volume sets
        .000      .000      .0
        .100      .0295     65.0
        .200      .0313     130.9
        .300      .0458     195.0
        .400      .0567     260.0
        .500      .0658     325.0
        .600      .0738     390.0
        .700      .0809     455.0
        .800      .0876     520.0
        .900      .195      585.0
        1.000     .386      650.0
Peak Outflow = .077 c.m/s
Maximum Depth = .647 metres
Maximum Storage = 421. c.m
        .012      .400      .077      .106 c.m/s
17  COMBINE
700  Junction Node No.

```

```

      .012      .400      .077      .177 c.m/s
14  START
    1  1=Zero; 2=Define
35  COMMENT
    3  line(s) of comment
    *****
    * AREA 101 *
    *****
4   CATCHMENT
101.000  ID No.6 99999
      .269  Area in hectares
20.000  Length (PERV) metres
2.000  Gradient (%)
4.000  Per cent Impervious
20.000  Length (IMPERV)
      .000  %Imp. with Zero Dpth
          1  Option 1=SCS CN/C; 2=Horton; 3=Green-Ampt; 4=Repeat
      .250  Manning "n"
71.000  SCS Curve No or C
      .100  Ia/S Coefficient
10.375  Initial Abstraction
          1  Option 1=Trianglr; 2=Rectanglr; 3=SWM HYD; 4=Lin. Reserv
      .017      .000      .077      .177 c.m/s
      .268      .897      .293      C perv/imperv/total
15  ADD RUNOFF
      .017      .017      .077      .177 c.m/s
35  COMMENT
    3  line(s) of comment
    *****
    * AREA 205 *
    *****
4   CATCHMENT
205.000  ID No.6 99999
      .368  Area in hectares
10.000  Length (PERV) metres
10.000  Gradient (%)
      .000  Per cent Impervious
10.000  Length (IMPERV)
      .000  %Imp. with Zero Dpth
          1  Option 1=SCS CN/C; 2=Horton; 3=Green-Ampt; 4=Repeat
      .250  Manning "n"
71.000  SCS Curve No or C
      .100  Ia/S Coefficient
10.375  Initial Abstraction
          1  Option 1=Trianglr; 2=Rectanglr; 3=SWM HYD; 4=Lin. Reserv
      .029      .017      .077      .177 c.m/s
      .266      .000      .266      C perv/imperv/total
15  ADD RUNOFF
      .029      .045      .077      .177 c.m/s
9   ROUTE
      .000  Conduit Length
      .000  No Conduit defined
      .000  Zero lag
      .000  Beta weighting factor
      .000  Routing timestep
          0  No. of sub-reaches
      .029      .045      .045      .177 c.m/s
17  COMBINE
700  Junction Node No.
      .029      .045      .045      .215 c.m/s
35  COMMENT
    3  line(s) of comment
    *****
    * PEAK FLOW TO EAST *
    *****
18  CONFLUENCE

```

```

700 Junction Node No.
      .029      .215      .045      .000 c.m/s
14  START
    1  1=Zero; 2=Define
35  COMMENT
    4  line(s) of comment
      *****
      * 25 YEAR CHICAGO STORM *
      * FERGUS SHAND DAM IDF PARAMETERS *
      *****
2  STORM
    1  1=Chicago;2=Huff;3=User;4=Cdn1hr;5=Historic
2957.749 Coefficient a
17.167 Constant b (min)
.907 Exponent c
.400 Fraction to peak r
180.000 Duration ó 240 min
      73.564 mm Total depth
3  IMPERVIOUS
    1  Option 1=SCS CN/C; 2=Horton; 3=Green-Ampt; 4=Repeat
      .013 Manning "n"
98.000 SCS Curve No or C
.100 Ia/S Coefficient
.518 Initial Abstraction
35  COMMENT
    3  line(s) of comment
      *****
      * EXISTING CONDITIONS *
      *****
35  COMMENT
    3  line(s) of comment
      *****
      * AREA 104 *
      *****
4  CATCHMENT
104.000 ID No.ó 99999
.382 Area in hectares
20.000 Length (PERV) metres
4.000 Gradient (%)
.000 Per cent Impervious
20.000 Length (IMPERV)
.000 %Imp. with Zero Dpth
1 Option 1=SCS CN/C; 2=Horton; 3=Green-Ampt; 4=Repeat
.250 Manning "n"
71.000 SCS Curve No or C
.100 Ia/S Coefficient
10.375 Initial Abstraction
1 Option 1=Trianglr; 2=Rectanglr; 3=SWM HYD; 4=Lin. Reserv
      .042      .000      .045      .000 c.m/s
      .323      .000      .323      C perv/imperv/total
35  COMMENT
    3  line(s) of comment
      *****
      * PEAK FLOW TO WEST *
      *****
15  ADD RUNOFF
      .042      .042      .045      .000 c.m/s
14  START
    1  1=Zero; 2=Define
35  COMMENT
    3  line(s) of comment
      *****
      * AREA 102 *
      *****
4  CATCHMENT
102.000 ID No.ó 99999

```

```

.928      Area in hectares
30.000    Length (PERV) metres
4.000     Gradient (%)
.000      Per cent Impervious
30.000    Length (IMPERV)
.000      %Imp. with Zero Dpth
1         Option 1=SCS CN/C; 2=Horton; 3=Green-Ampt; 4=Repeat
.250      Manning "n"
71.000    SCS Curve No or C
.100      Ia/S Coefficient
10.375    Initial Abstraction
1         Option 1=Trianglr; 2=Rectanglr; 3=SWM HYD; 4=Lin. Reserv
.090      .000      .045      .000 c.m/s
.324      .000      .324      C perv/imperv/total
15  ADD RUNOFF
.090      .090      .045      .000 c.m/s
9   ROUTE
.000      Conduit Length
.000      No Conduit defined
.000      Zero lag
.000      Beta weighting factor
.000      Routing timestep
0         No. of sub-reaches
.090      .090      .090      .000 c.m/s
17  COMBINE
500      Junction Node No.
.090      .090      .090      .090 c.m/s
14  START
1         1=Zero; 2=Define
35  COMMENT
3         line(s) of comment
*****
* AREA 103 *
*****
4   CATCHMENT
103.000   ID No.6 99999
.069     Area in hectares
10.000   Length (PERV) metres
2.000    Gradient (%)
72.000   Per cent Impervious
10.000   Length (IMPERV)
.000     %Imp. with Zero Dpth
1        Option 1=SCS CN/C; 2=Horton; 3=Green-Ampt; 4=Repeat
.250     Manning "n"
71.000   SCS Curve No or C
.100     Ia/S Coefficient
10.375   Initial Abstraction
1        Option 1=Trianglr; 2=Rectanglr; 3=SWM HYD; 4=Lin. Reserv
.022     .000     .090     .090 c.m/s
.324     .885     .728     C perv/imperv/total
15  ADD RUNOFF
.022     .022     .090     .090 c.m/s
9   ROUTE
.000     Conduit Length
.000     No Conduit defined
.000     Zero lag
.000     Beta weighting factor
.000     Routing timestep
0        No. of sub-reaches
.022     .022     .022     .090 c.m/s
17  COMBINE
500     Junction Node No.
.022     .022     .022     .098 c.m/s
18  CONFLUENCE
500     Junction Node No.
.022     .098     .022     .000 c.m/s

```

```

35  COMMENT
    3  line(s) of comment
    *****
    * AREA 107 *
    *****
4  CATCHMENT
107.000  ID No.6 99999
    2.560  Area in hectares
    50.000  Length (PERV) metres
    4.000  Gradient (%)
    1.000  Per cent Impervious
    50.000  Length (IMPERV)
    .000  %Imp. with Zero Dpth
    1  Option 1=SCS CN/C; 2=Horton; 3=Green-Ampt; 4=Repeat
    .250  Manning "n"
    71.000  SCS Curve No or C
    .100  Ia/S Coefficient
    10.375  Initial Abstraction
    1  Option 1=Trianglr; 2=Rectanglr; 3=SWM HYD; 4=Lin. Reserv
    .220  .098  .022  .000 c.m/s
    .325  .915  .331  C perv/imperv/total
15  ADD RUNOFF
    .220  .318  .022  .000 c.m/s
9  ROUTE
    .000  Conduit Length
    .000  No Conduit defined
    .000  Zero lag
    .000  Beta weighting factor
    .000  Routing timestep
    0  No. of sub-reaches
    .220  .318  .318  .000 c.m/s
17  COMBINE
    600  Junction Node No.
    .220  .318  .318  .318 c.m/s
14  START
    1  1=Zero; 2=Define
35  COMMENT
    3  line(s) of comment
    *****
    * AREA 101 *
    *****
4  CATCHMENT
101.000  ID No.6 99999
    .269  Area in hectares
    20.000  Length (PERV) metres
    2.000  Gradient (%)
    4.000  Per cent Impervious
    20.000  Length (IMPERV)
    .000  %Imp. with Zero Dpth
    1  Option 1=SCS CN/C; 2=Horton; 3=Green-Ampt; 4=Repeat
    .250  Manning "n"
    71.000  SCS Curve No or C
    .100  Ia/S Coefficient
    10.375  Initial Abstraction
    1  Option 1=Trianglr; 2=Rectanglr; 3=SWM HYD; 4=Lin. Reserv
    .027  .000  .318  .318 c.m/s
    .324  .910  .347  C perv/imperv/total
15  ADD RUNOFF
    .027  .027  .318  .318 c.m/s
35  COMMENT
    3  line(s) of comment
    *****
    * AREA 105 *
    *****
4  CATCHMENT
105.000  ID No.6 99999

```

```

.533      Area in hectares
20.000    Length (PERV) metres
4.000     Gradient (%)
.000      Per cent Impervious
20.000    Length (IMPERV)
.000      %Imp. with Zero Dpth
1         Option 1=SCS CN/C; 2=Horton; 3=Green-Ampt; 4=Repeat
.250      Manning "n"
71.000    SCS Curve No or C
.100      Ia/S Coefficient
10.375    Initial Abstraction
1         Option 1=Trianglr; 2=Rectanglr; 3=SWM HYD; 4=Lin. Reserv
          .058      .027      .318      .318 c.m/s
          .323      .000      .323      C perv/imperv/total
15  ADD RUNOFF
          .058      .085      .318      .318 c.m/s
9   ROUTE
          .000      Conduit Length
          .000      No Conduit defined
          .000      Zero lag
          .000      Beta weighting factor
          .000      Routing timestep
          0        No. of sub-reaches
          .058      .085      .085      .318 c.m/s
17  COMBINE
600  Junction Node No.
          .058      .085      .085      .398 c.m/s
14  START
1    1=Zero; 2=Define
35  COMMENT
3    line(s) of comment
*****
* AREA 106 *
*****
4   CATCHMENT
106.000   ID No.6 99999
.147     Area in hectares
20.000   Length (PERV) metres
4.000    Gradient (%)
.000     Per cent Impervious
20.000   Length (IMPERV)
.000     %Imp. with Zero Dpth
1        Option 1=SCS CN/C; 2=Horton; 3=Green-Ampt; 4=Repeat
.250     Manning "n"
71.000   SCS Curve No or C
.100     Ia/S Coefficient
10.375   Initial Abstraction
1        Option 1=Trianglr; 2=Rectanglr; 3=SWM HYD; 4=Lin. Reserv
          .016      .000      .085      .398 c.m/s
          .323      .000      .323      C perv/imperv/total
15  ADD RUNOFF
          .016      .016      .085      .398 c.m/s
9   ROUTE
          .000      Conduit Length
          .000      No Conduit defined
          .000      Zero lag
          .000      Beta weighting factor
          .000      Routing timestep
          0        No. of sub-reaches
          .016      .016      .016      .398 c.m/s
17  COMBINE
600  Junction Node No.
          .016      .016      .016      .413 c.m/s
35  COMMENT
3    line(s) of comment
*****

```

```

* PEAK FLOW TO EAST *
*****
18  CONFLUENCE
600  Junction Node No.
      .016      .413      .016      .000 c.m/s
14  START
1    1=Zero; 2=Define
35  COMMENT
3    line(s) of comment
*****
* PROPOSED CONDITIONS *
*****
35  COMMENT
3    line(s) of comment
*****
* AREA 202 *
*****
4    CATCHMENT
202.000  ID No.6 99999
      .337  Area in hectares
20.000   Length (PERV) metres
4.000   Gradient (%)
      .000   Per cent Impervious
20.000   Length (IMPERV)
      .000   %Imp. with Zero Dpth
      1    Option 1=SCS CN/C; 2=Horton; 3=Green-Ampt; 4=Repeat
      .250   Manning "n"
71.000   SCS Curve No or C
      .100   Ia/S Coefficient
10.375   Initial Abstraction
      1    Option 1=Trianglr; 2=Rectanglr; 3=SWM HYD; 4=Lin. Reserv
      .037   .000   .016   .000 c.m/s
      .323   .000   .323   C perv/imperv/total
35  COMMENT
3    line(s) of comment
*****
* PEAK FLOW TO WEST *
*****
15  ADD RUNOFF
      .037   .037   .016   .000 c.m/s
14  START
1    1=Zero; 2=Define
35  COMMENT
3    line(s) of comment
*****
* AREA 102 *
*****
4    CATCHMENT
102.000  ID No.6 99999
      .928  Area in hectares
30.000   Length (PERV) metres
4.000   Gradient (%)
      .000   Per cent Impervious
30.000   Length (IMPERV)
      .000   %Imp. with Zero Dpth
      1    Option 1=SCS CN/C; 2=Horton; 3=Green-Ampt; 4=Repeat
      .250   Manning "n"
71.000   SCS Curve No or C
      .100   Ia/S Coefficient
10.375   Initial Abstraction
      1    Option 1=Trianglr; 2=Rectanglr; 3=SWM HYD; 4=Lin. Reserv
      .090   .000   .016   .000 c.m/s
      .324   .000   .324   C perv/imperv/total
15  ADD RUNOFF
      .090   .090   .016   .000 c.m/s
35  COMMENT

```

```

3   line(s) of comment
*****
* AREA 203 *
*****
4   CATCHMENT
203.000  ID No.ó 99999
    .648  Area in hectares
20.000   Length (PERV) metres
    4.000 Gradient (%)
    .000  Per cent Impervious
20.000   Length (IMPERV)
    .000  %Imp. with Zero Dpth
    1     Option 1=SCS CN/C; 2=Horton; 3=Green-Ampt; 4=Repeat
    .250  Manning "n"
71.000   SCS Curve No or C
    .100  Ia/S Coefficient
10.375   Initial Abstraction
    1     Option 1=Trianglr; 2=Rectanglr; 3=SWM HYD; 4=Lin. Reserv
        .071  .090  .016  .000 c.m/s
        .323  .000  .323  C perv/imperv/total
15  ADD RUNOFF
        .071  .158  .016  .000 c.m/s
35  COMMENT
3   line(s) of comment
*****
* AREA 103 *
*****
4   CATCHMENT
103.000  ID No.ó 99999
    .069  Area in hectares
10.000   Length (PERV) metres
    2.000 Gradient (%)
72.000   Per cent Impervious
10.000   Length (IMPERV)
    .000  %Imp. with Zero Dpth
    1     Option 1=SCS CN/C; 2=Horton; 3=Green-Ampt; 4=Repeat
    .250  Manning "n"
71.000   SCS Curve No or C
    .100  Ia/S Coefficient
10.375   Initial Abstraction
    1     Option 1=Trianglr; 2=Rectanglr; 3=SWM HYD; 4=Lin. Reserv
        .022  .158  .016  .000 c.m/s
        .324  .885  .728  C perv/imperv/total
15  ADD RUNOFF
        .022  .169  .016  .000 c.m/s
9   ROUTE
    .000  Conduit Length
    .000  No Conduit defined
    .000  Zero lag
    .000  Beta weighting factor
    .000  Routing timestep
    0     No. of sub-reaches
        .022  .169  .169  .000 c.m/s
17  COMBINE
700  Junction Node No.
    .022  .169  .169  .169 c.m/s
14  START
    1     1=Zero; 2=Define
35  COMMENT
3   line(s) of comment
*****
* AREA 201 *
*****
4   CATCHMENT
201.000  ID No.ó 99999
    2.110 Area in hectares

```

```

20.000 Length (PERV) metres
4.000 Gradient (%)
50.000 Per cent Impervious
20.000 Length (IMPERV)
.000 %Imp. with Zero Dpth
1 Option 1=SCS CN/C; 2=Horton; 3=Green-Ampt; 4=Repeat
.250 Manning "n"
71.000 SCS Curve No or C
.100 Ia/S Coefficient
10.375 Initial Abstraction
1 Option 1=Trianglr; 2=Rectanglr; 3=SWM HYD; 4=Lin. Reserv
.481 .000 .169 .169 c.m/s
.323 .900 .611 C perv/imperv/total
15 ADD RUNOFF
.481 .481 .169 .169 c.m/s
35 COMMENT
3 line(s) of comment
*****
* AREA 204 *
*****
4 CATCHMENT
204.000 ID No.ó 99999
.145 Area in hectares
10.000 Length (PERV) metres
2.000 Gradient (%)
10.000 Per cent Impervious
10.000 Length (IMPERV)
.000 %Imp. with Zero Dpth
1 Option 1=SCS CN/C; 2=Horton; 3=Green-Ampt; 4=Repeat
.250 Manning "n"
71.000 SCS Curve No or C
.100 Ia/S Coefficient
10.375 Initial Abstraction
1 Option 1=Trianglr; 2=Rectanglr; 3=SWM HYD; 4=Lin. Reserv
.018 .481 .169 .169 c.m/s
.324 .885 .380 C perv/imperv/total
15 ADD RUNOFF
.018 .491 .169 .169 c.m/s
35 COMMENT
3 line(s) of comment
*****
* UNDERGROUND STORAGE *
*****
10 POND
11 Depth - Discharge - Volume sets
.000 .000 .0
.100 .0295 65.0
.200 .0313 130.9
.300 .0458 195.0
.400 .0567 260.0
.500 .0658 325.0
.600 .0738 390.0
.700 .0809 455.0
.800 .0876 520.0
.900 .195 585.0
1.000 .386 650.0
Peak Outflow = .129 c.m/s
Maximum Depth = .838 metres
Maximum Storage = 545. c.m
.018 .491 .129 .169 c.m/s
17 COMBINE
700 Junction Node No.
.018 .491 .129 .248 c.m/s
14 START
1 1=Zero; 2=Define
35 COMMENT

```

```

3   line(s) of comment
*****
* AREA 101 *
*****
4   CATCHMENT
101.000 ID No.ó 99999
    .269 Area in hectares
20.000 Length (PERV) metres
    2.000 Gradient (%)
    4.000 Per cent Impervious
20.000 Length (IMPERV)
    .000 %Imp. with Zero Dpth
    1 Option 1=SCS CN/C; 2=Horton; 3=Green-Ampt; 4=Repeat
    .250 Manning "n"
71.000 SCS Curve No or C
    .100 Ia/S Coefficient
10.375 Initial Abstraction
    1 Option 1=Trianglr; 2=Rectanglr; 3=SWM HYD; 4=Lin. Reserv
      .027 .000 .129 .248 c.m/s
      .324 .910 .347 C perv/imperv/total
15  ADD RUNOFF
      .027 .027 .129 .248 c.m/s
35  COMMENT
3   line(s) of comment
*****
* AREA 205 *
*****
4   CATCHMENT
205.000 ID No.ó 99999
    .368 Area in hectares
10.000 Length (PERV) metres
10.000 Gradient (%)
    .000 Per cent Impervious
10.000 Length (IMPERV)
    .000 %Imp. with Zero Dpth
    1 Option 1=SCS CN/C; 2=Horton; 3=Green-Ampt; 4=Repeat
    .250 Manning "n"
71.000 SCS Curve No or C
    .100 Ia/S Coefficient
10.375 Initial Abstraction
    1 Option 1=Trianglr; 2=Rectanglr; 3=SWM HYD; 4=Lin. Reserv
      .047 .027 .129 .248 c.m/s
      .323 .000 .323 C perv/imperv/total
15  ADD RUNOFF
      .047 .069 .129 .248 c.m/s
9   ROUTE
    .000 Conduit Length
    .000 No Conduit defined
    .000 Zero lag
    .000 Beta weighting factor
    .000 Routing timestep
    0 No. of sub-reaches
      .047 .069 .069 .248 c.m/s
17  COMBINE
700 Junction Node No.
      .047 .069 .069 .315 c.m/s
35  COMMENT
3   line(s) of comment
*****
* PEAK FLOW TO EAST *
*****
18  CONFLUENCE
700 Junction Node No.
      .047 .315 .069 .000 c.m/s
14  START
1   1=Zero; 2=Define

```

```

35  COMMENT
4    line(s) of comment
*****
* 50 YEAR CHICAGO STORM *
* FERGUS SHAND DAM IDF PARAMETERS *
*****
2    STORM
1    1=Chicago;2=Huff;3=User;4=Cdn1hr;5=Historic
3705.143 Coefficient a
19.206 Constant b (min)
.924 Exponent c
.400 Fraction to peak r
180.000 Duration ó 240 min
83.439 mm Total depth
3    IMPERVIOUS
1    Option 1=SCS CN/C; 2=Horton; 3=Green-Ampt; 4=Repeat
.013 Manning "n"
98.000 SCS Curve No or C
.100 Ia/S Coefficient
.518 Initial Abstraction
35  COMMENT
3    line(s) of comment
*****
* EXISTING CONDITIONS *
*****
35  COMMENT
3    line(s) of comment
*****
* AREA 104 *
*****
4    CATCHMENT
104.000 ID No.ó 99999
.382 Area in hectares
20.000 Length (PERV) metres
4.000 Gradient (%)
.000 Per cent Impervious
20.000 Length (IMPERV)
.000 %Imp. with Zero Dpth
1    Option 1=SCS CN/C; 2=Horton; 3=Green-Ampt; 4=Repeat
.250 Manning "n"
71.000 SCS Curve No or C
.100 Ia/S Coefficient
10.375 Initial Abstraction
1    Option 1=Trianglr; 2=Rectanglr; 3=SWM HYD; 4=Lin. Reserv
.055 .000 .069 .000 c.m/s
.360 .000 .360 C perv/imperv/total
35  COMMENT
3    line(s) of comment
*****
* PEAK FLOW TO WEST *
*****
15  ADD RUNOFF
.055 .055 .069 .000 c.m/s
14  START
1    1=Zero; 2=Define
35  COMMENT
3    line(s) of comment
*****
* AREA 102 *
*****
4    CATCHMENT
102.000 ID No.ó 99999
.928 Area in hectares
30.000 Length (PERV) metres
4.000 Gradient (%)
.000 Per cent Impervious

```

```

30.000 Length (IMPERV)
.000 %Imp. with Zero Dpth
1 Option 1=SCS CN/C; 2=Horton; 3=Green-Ampt; 4=Repeat
.250 Manning "n"
71.000 SCS Curve No or C
.100 Ia/S Coefficient
10.375 Initial Abstraction
1 Option 1=Trianglr; 2=Rectanglr; 3=SWM HYD; 4=Lin. Reserv
.119 .000 .069 .000 c.m/s
.361 .000 .361 C perv/imperv/total
15 ADD RUNOFF
.119 .119 .069 .000 c.m/s
9 ROUTE
.000 Conduit Length
.000 No Conduit defined
.000 Zero lag
.000 Beta weighting factor
.000 Routing timestep
0 No. of sub-reaches
.119 .119 .119 .000 c.m/s
17 COMBINE
500 Junction Node No.
.119 .119 .119 .119 c.m/s
14 START
1 1=Zero; 2=Define
35 COMMENT
3 line(s) of comment
*****
* AREA 103 *
*****
4 CATCHMENT
103.000 ID No.6 99999
.069 Area in hectares
10.000 Length (PERV) metres
2.000 Gradient (%)
72.000 Per cent Impervious
10.000 Length (IMPERV)
.000 %Imp. with Zero Dpth
1 Option 1=SCS CN/C; 2=Horton; 3=Green-Ampt; 4=Repeat
.250 Manning "n"
71.000 SCS Curve No or C
.100 Ia/S Coefficient
10.375 Initial Abstraction
1 Option 1=Trianglr; 2=Rectanglr; 3=SWM HYD; 4=Lin. Reserv
.024 .000 .119 .119 c.m/s
.360 .890 .741 C perv/imperv/total
15 ADD RUNOFF
.024 .024 .119 .119 c.m/s
9 ROUTE
.000 Conduit Length
.000 No Conduit defined
.000 Zero lag
.000 Beta weighting factor
.000 Routing timestep
0 No. of sub-reaches
.024 .024 .024 .119 c.m/s
17 COMBINE
500 Junction Node No.
.024 .024 .024 .132 c.m/s
18 CONFLUENCE
500 Junction Node No.
.024 .132 .024 .000 c.m/s
35 COMMENT
3 line(s) of comment
*****
* AREA 107 *

```

```

*****
4  CATCHMENT
107.000  ID No.6 99999
2.560   Area in hectares
50.000  Length (PERV) metres
4.000   Gradient (%)
1.000   Per cent Impervious
50.000  Length (IMPERV)
.000    %Imp. with Zero Dpth
1       Option 1=SCS CN/C; 2=Horton; 3=Green-Ampt; 4=Repeat
.250    Manning "n"
71.000  SCS Curve No or C
.100    Ia/S Coefficient
10.375  Initial Abstraction
1       Option 1=Trianglr; 2=Rectanglr; 3=SWM HYD; 4=Lin. Reserv
        .296    .132    .024    .000 c.m/s
        .361    .923    .367    C perv/imperv/total
15  ADD RUNOFF
        .296    .423    .024    .000 c.m/s
9   ROUTE
.000    Conduit Length
.000    No Conduit defined
.000    Zero lag
.000    Beta weighting factor
.000    Routing timestep
0       No. of sub-reaches
        .296    .423    .423    .000 c.m/s
17  COMBINE
600    Junction Node No.
        .296    .423    .423    .423 c.m/s
14  START
1      1=Zero; 2=Define
35  COMMENT
3      line(s) of comment
*****
* AREA 101 *
*****
4  CATCHMENT
101.000  ID No.6 99999
.269    Area in hectares
20.000  Length (PERV) metres
2.000   Gradient (%)
4.000   Per cent Impervious
20.000  Length (IMPERV)
.000    %Imp. with Zero Dpth
1       Option 1=SCS CN/C; 2=Horton; 3=Green-Ampt; 4=Repeat
.250    Manning "n"
71.000  SCS Curve No or C
.100    Ia/S Coefficient
10.375  Initial Abstraction
1       Option 1=Trianglr; 2=Rectanglr; 3=SWM HYD; 4=Lin. Reserv
        .036    .000    .423    .423 c.m/s
        .361    .917    .383    C perv/imperv/total
15  ADD RUNOFF
        .036    .036    .423    .423 c.m/s
35  COMMENT
3      line(s) of comment
*****
* AREA 105 *
*****
4  CATCHMENT
105.000  ID No.6 99999
.533    Area in hectares
20.000  Length (PERV) metres
4.000   Gradient (%)
.000    Per cent Impervious

```

```

20.000 Length (IMPERV)
.000 %Imp. with Zero Dpth
1 Option 1=SCS CN/C; 2=Horton; 3=Green-Ampt; 4=Repeat
.250 Manning "n"
71.000 SCS Curve No or C
.100 Ia/S Coefficient
10.375 Initial Abstraction
1 Option 1=Trianglr; 2=Rectanglr; 3=SWM HYD; 4=Lin. Reserv
.077 .036 .423 .423 c.m/s
.360 .000 .360 C perv/imperv/total
15 ADD RUNOFF
.077 .113 .423 .423 c.m/s
9 ROUTE
.000 Conduit Length
.000 No Conduit defined
.000 Zero lag
.000 Beta weighting factor
.000 Routing timestep
0 No. of sub-reaches
.077 .113 .113 .423 c.m/s
17 COMBINE
600 Junction Node No.
.077 .113 .113 .524 c.m/s
14 START
1 1=Zero; 2=Define
35 COMMENT
3 line(s) of comment
*****
* AREA 106 *
*****
4 CATCHMENT
106.000 ID No.6 99999
.147 Area in hectares
20.000 Length (PERV) metres
4.000 Gradient (%)
.000 Per cent Impervious
20.000 Length (IMPERV)
.000 %Imp. with Zero Dpth
1 Option 1=SCS CN/C; 2=Horton; 3=Green-Ampt; 4=Repeat
.250 Manning "n"
71.000 SCS Curve No or C
.100 Ia/S Coefficient
10.375 Initial Abstraction
1 Option 1=Trianglr; 2=Rectanglr; 3=SWM HYD; 4=Lin. Reserv
.021 .000 .113 .524 c.m/s
.360 .000 .360 C perv/imperv/total
15 ADD RUNOFF
.021 .021 .113 .524 c.m/s
9 ROUTE
.000 Conduit Length
.000 No Conduit defined
.000 Zero lag
.000 Beta weighting factor
.000 Routing timestep
0 No. of sub-reaches
.021 .021 .021 .524 c.m/s
17 COMBINE
600 Junction Node No.
.021 .021 .021 .542 c.m/s
35 COMMENT
3 line(s) of comment
*****
* PEAK FLOW TO EAST *
*****
18 CONFLUENCE
600 Junction Node No.

```

```

        .021      .542      .021      .000 c.m/s
14  START
1    1=Zero; 2=Define
35  COMMENT
3    line(s) of comment
*****
* PROPOSED CONDITIONS *
*****
35  COMMENT
3    line(s) of comment
*****
* AREA 202 *
*****
4    CATCHMENT
202.000  ID No.6 99999
      .337  Area in hectares
20.000  Length (PERV) metres
4.000  Gradient (%)
      .000  Per cent Impervious
20.000  Length (IMPERV)
      .000  %Imp. with Zero Dpth
      1    Option 1=SCS CN/C; 2=Horton; 3=Green-Ampt; 4=Repeat
      .250  Manning "n"
71.000  SCS Curve No or C
      .100  Ia/S Coefficient
10.375  Initial Abstraction
      1    Option 1=Trianglr; 2=Rectanglr; 3=SWM HYD; 4=Lin. Reserv
          .049      .000      .021      .000 c.m/s
          .360      .000      .360      C perv/imperv/total
35  COMMENT
3    line(s) of comment
*****
* PEAK FLOW TO WEST *
*****
15  ADD RUNOFF
      .049      .049      .021      .000 c.m/s
14  START
1    1=Zero; 2=Define
35  COMMENT
3    line(s) of comment
*****
* AREA 102 *
*****
4    CATCHMENT
102.000  ID No.6 99999
      .928  Area in hectares
30.000  Length (PERV) metres
4.000  Gradient (%)
      .000  Per cent Impervious
30.000  Length (IMPERV)
      .000  %Imp. with Zero Dpth
      1    Option 1=SCS CN/C; 2=Horton; 3=Green-Ampt; 4=Repeat
      .250  Manning "n"
71.000  SCS Curve No or C
      .100  Ia/S Coefficient
10.375  Initial Abstraction
      1    Option 1=Trianglr; 2=Rectanglr; 3=SWM HYD; 4=Lin. Reserv
          .119      .000      .021      .000 c.m/s
          .361      .000      .361      C perv/imperv/total
15  ADD RUNOFF
      .119      .119      .021      .000 c.m/s
35  COMMENT
3    line(s) of comment
*****
* AREA 203 *
*****

```

```

4   CATCHMENT
203.000  ID No.ó 99999
      .648  Area in hectares
20.000   Length (PERV) metres
4.000   Gradient (%)
      .000  Per cent Impervious
20.000   Length (IMPERV)
      .000  %Imp. with Zero Dpth
      1    Option 1=SCS CN/C; 2=Horton; 3=Green-Ampt; 4=Repeat
      .250  Manning "n"
71.000   SCS Curve No or C
      .100  Ia/S Coefficient
10.375   Initial Abstraction
      1    Option 1=Trianglr; 2=Rectanglr; 3=SWM HYD; 4=Lin. Reserv
      .094   .119   .021   .000 c.m/s
      .360   .000   .360   C perv/imperv/total
15  ADD RUNOFF
      .094   .213   .021   .000 c.m/s
35  COMMENT
3     line(s) of comment
*****
* AREA 103 *
*****
4   CATCHMENT
103.000  ID No.ó 99999
      .069  Area in hectares
10.000   Length (PERV) metres
2.000   Gradient (%)
72.000   Per cent Impervious
10.000   Length (IMPERV)
      .000  %Imp. with Zero Dpth
      1    Option 1=SCS CN/C; 2=Horton; 3=Green-Ampt; 4=Repeat
      .250  Manning "n"
71.000   SCS Curve No or C
      .100  Ia/S Coefficient
10.375   Initial Abstraction
      1    Option 1=Trianglr; 2=Rectanglr; 3=SWM HYD; 4=Lin. Reserv
      .024   .213   .021   .000 c.m/s
      .360   .890   .741   C perv/imperv/total
15  ADD RUNOFF
      .024   .226   .021   .000 c.m/s
9   ROUTE
      .000   Conduit Length
      .000   No Conduit defined
      .000   Zero lag
      .000   Beta weighting factor
      .000   Routing timestep
      0     No. of sub-reaches
      .024   .226   .226   .000 c.m/s
17  COMBINE
700   Junction Node No.
      .024   .226   .226   .226 c.m/s
14  START
1     1=Zero; 2=Define
35  COMMENT
3     line(s) of comment
*****
* AREA 201 *
*****
4   CATCHMENT
201.000  ID No.ó 99999
      2.110  Area in hectares
20.000   Length (PERV) metres
4.000   Gradient (%)
50.000   Per cent Impervious
20.000   Length (IMPERV)

```

```

.000 %Imp. with Zero Dpth
1 Option 1=SCS CN/C; 2=Horton; 3=Green-Ampt; 4=Repeat
.250 Manning "n"
71.000 SCS Curve No or C
.100 Ia/S Coefficient
10.375 Initial Abstraction
1 Option 1=Trianglr; 2=Rectanglr; 3=SWM HYD; 4=Lin. Reserv
.545 .000 .226 .226 c.m/s
.360 .905 .633 C perv/imperv/total
15 ADD RUNOFF
.545 .545 .226 .226 c.m/s
35 COMMENT
3 line(s) of comment
*****
* AREA 204 *
*****
4 CATCHMENT
204.000 ID No.ó 99999
.145 Area in hectares
10.000 Length (PERV) metres
2.000 Gradient (%)
10.000 Per cent Impervious
10.000 Length (IMPERV)
.000 %Imp. with Zero Dpth
1 Option 1=SCS CN/C; 2=Horton; 3=Green-Ampt; 4=Repeat
.250 Manning "n"
71.000 SCS Curve No or C
.100 Ia/S Coefficient
10.375 Initial Abstraction
1 Option 1=Trianglr; 2=Rectanglr; 3=SWM HYD; 4=Lin. Reserv
.024 .545 .226 .226 c.m/s
.360 .890 .413 C perv/imperv/total
15 ADD RUNOFF
.024 .558 .226 .226 c.m/s
35 COMMENT
3 line(s) of comment
*****
* UNDERGROUND STORAGE *
*****
10 POND
11 Depth - Discharge - Volume sets
.000 .000 .0
.100 .0295 65.0
.200 .0313 130.9
.300 .0458 195.0
.400 .0567 260.0
.500 .0658 325.0
.600 .0738 390.0
.700 .0809 455.0
.800 .0876 520.0
.900 .195 585.0
1.000 .386 650.0
Peak Outflow = .214 c.m/s
Maximum Depth = .910 metres
Maximum Storage = 592. c.m
.024 .558 .214 .226 c.m/s
17 COMBINE
700 Junction Node No.
.024 .558 .214 .374 c.m/s
14 START
1 1=Zero; 2=Define
35 COMMENT
3 line(s) of comment
*****
* AREA 101 *
*****

```

```

4   CATCHMENT
101.000  ID No.ó 99999
      .269  Area in hectares
20.000   Length (PERV) metres
2.000   Gradient (%)
4.000   Per cent Impervious
20.000   Length (IMPERV)
      .000  %Imp. with Zero Dpth
          1  Option 1=SCS CN/C; 2=Horton; 3=Green-Ampt; 4=Repeat
      .250  Manning "n"
71.000   SCS Curve No or C
      .100  Ia/S Coefficient
10.375   Initial Abstraction
          1  Option 1=Trianglr; 2=Rectanglr; 3=SWM HYD; 4=Lin. Reserv
      .036   .000   .214   .374 c.m/s
      .361   .917   .383   C perv/imperv/total
15  ADD RUNOFF
      .036   .036   .214   .374 c.m/s
35  COMMENT
3     line(s) of comment
*****
* AREA 205 *
*****
4   CATCHMENT
205.000  ID No.ó 99999
      .368  Area in hectares
10.000   Length (PERV) metres
10.000   Gradient (%)
      .000  Per cent Impervious
10.000   Length (IMPERV)
      .000  %Imp. with Zero Dpth
          1  Option 1=SCS CN/C; 2=Horton; 3=Green-Ampt; 4=Repeat
      .250  Manning "n"
71.000   SCS Curve No or C
      .100  Ia/S Coefficient
10.375   Initial Abstraction
          1  Option 1=Trianglr; 2=Rectanglr; 3=SWM HYD; 4=Lin. Reserv
      .062   .036   .214   .374 c.m/s
      .359   .000   .359   C perv/imperv/total
15  ADD RUNOFF
      .062   .090   .214   .374 c.m/s
9   ROUTE
      .000  Conduit Length
      .000  No Conduit defined
      .000  Zero lag
      .000  Beta weighting factor
      .000  Routing timestep
          0  No. of sub-reaches
      .062   .090   .090   .374 c.m/s
17  COMBINE
700  Junction Node No.
      .062   .090   .090   .444 c.m/s
35  COMMENT
3     line(s) of comment
*****
* PEAK FLOW TO EAST *
*****
18  CONFLUENCE
700  Junction Node No.
      .062   .444   .090   .000 c.m/s
14  START
1     1=Zero; 2=Define
35  COMMENT
4     line(s) of comment
*****
* 100 YEAR CHICAGO STORM *

```

* FERGUS SHAND DAM IDF PARAMETERS *

```

2   STORM
    1      1=Chicago;2=Huff;3=User;4=Cdn1hr;5=Historic
4448.166 Coefficient a
    20.416 Constant b (min)
    .936   Exponent c
    .400   Fraction to peak r
    180.000 Duration ó 240 min
          93.475 mm Total depth
3   IMPERVIOUS
    1      Option 1=SCS CN/C; 2=Horton; 3=Green-Ampt; 4=Repeat
    .013   Manning "n"
    98.000 SCS Curve No or C
    .100   Ia/S Coefficient
    .518   Initial Abstraction
35  COMMENT
    3      line(s) of comment
    *****
    * EXISTING CONDITIONS *
    *****
35  COMMENT
    3      line(s) of comment
    *****
    * AREA 104 *
    *****
4   CATCHMENT
    104.000 ID No.ó 99999
    .382   Area in hectares
    20.000 Length (PERV) metres
    4.000  Gradient (%)
    .000   Per cent Impervious
    20.000 Length (IMPERV)
    .000   %Imp. with Zero Dpth
    1      Option 1=SCS CN/C; 2=Horton; 3=Green-Ampt; 4=Repeat
    .250   Manning "n"
    71.000 SCS Curve No or C
    .100   Ia/S Coefficient
    10.375 Initial Abstraction
    1      Option 1=Trianglr; 2=Rectanglr; 3=SWM HYD; 4=Lin. Reserv
          .070   .000   .090   .000 c.m/s
          .394   .000   .394   C perv/imperv/total
35  COMMENT
    3      line(s) of comment
    *****
    * PEAK FLOW TO WEST *
    *****
15  ADD RUNOFF
    .070   .070   .090   .000 c.m/s
14  START
    1      1=Zero; 2=Define
35  COMMENT
    3      line(s) of comment
    *****
    * AREA 102 *
    *****
4   CATCHMENT
    102.000 ID No.ó 99999
    .928   Area in hectares
    30.000 Length (PERV) metres
    4.000  Gradient (%)
    .000   Per cent Impervious
    30.000 Length (IMPERV)
    .000   %Imp. with Zero Dpth
    1      Option 1=SCS CN/C; 2=Horton; 3=Green-Ampt; 4=Repeat
    .250   Manning "n"
  
```

```

71.000    SCS Curve No or C
.100      Ia/S Coefficient
10.375    Initial Abstraction
  1       Option 1=Trianglr; 2=Rectanglr; 3=SWM HYD; 4=Lin. Reserv
        .155      .000      .090      .000 c.m/s
        .394      .000      .394      C perv/imperv/total
15  ADD RUNOFF
        .155      .155      .090      .000 c.m/s
  9  ROUTE
        .000      Conduit Length
        .000      No Conduit defined
        .000      Zero lag
        .000      Beta weighting factor
        .000      Routing timestep
        0       No. of sub-reaches
        .155      .155      .155      .000 c.m/s
17  COMBINE
500      Junction Node No.
        .155      .155      .155      .155 c.m/s
14  START
  1       1=Zero; 2=Define
35  COMMENT
  3       line(s) of comment
        *****
        * AREA 103 *
        *****
  4  CATCHMENT
103.000   ID No.ó 99999
        .069      Area in hectares
10.000   Length (PERV) metres
  2.000   Gradient (%)
72.000   Per cent Impervious
10.000   Length (IMPERV)
        .000      %Imp. with Zero Dpth
        1       Option 1=SCS CN/C; 2=Horton; 3=Green-Ampt; 4=Repeat
        .250      Manning "n"
71.000   SCS Curve No or C
        .100      Ia/S Coefficient
10.375   Initial Abstraction
  1       Option 1=Trianglr; 2=Rectanglr; 3=SWM HYD; 4=Lin. Reserv
        .027      .000      .155      .155 c.m/s
        .391      .892      .752      C perv/imperv/total
15  ADD RUNOFF
        .027      .027      .155      .155 c.m/s
  9  ROUTE
        .000      Conduit Length
        .000      No Conduit defined
        .000      Zero lag
        .000      Beta weighting factor
        .000      Routing timestep
        0       No. of sub-reaches
        .027      .027      .027      .155 c.m/s
17  COMBINE
500      Junction Node No.
        .027      .027      .027      .170 c.m/s
18  CONFLUENCE
500      Junction Node No.
        .027      .170      .027      .000 c.m/s
35  COMMENT
  3       line(s) of comment
        *****
        * AREA 107 *
        *****
  4  CATCHMENT
107.000   ID No.ó 99999
        2.560      Area in hectares

```

```

50.000 Length (PERV) metres
4.000 Gradient (%)
1.000 Per cent Impervious
50.000 Length (IMPERV)
.000 %Imp. with Zero Dpth
1 Option 1=SCS CN/C; 2=Horton; 3=Green-Ampt; 4=Repeat
.250 Manning "n"
71.000 SCS Curve No or C
.100 Ia/S Coefficient
10.375 Initial Abstraction
1 Option 1=Trianglr; 2=Rectanglr; 3=SWM HYD; 4=Lin. Reserv
.389 .170 .027 .000 c.m/s
.395 .930 .400 C perv/imperv/total
15 ADD RUNOFF
.389 .546 .027 .000 c.m/s
9 ROUTE
.000 Conduit Length
.000 No Conduit defined
.000 Zero lag
.000 Beta weighting factor
.000 Routing timestep
0 No. of sub-reaches
.389 .546 .546 .000 c.m/s
17 COMBINE
600 Junction Node No.
.389 .546 .546 .546 c.m/s
14 START
1 1=Zero; 2=Define
35 COMMENT
3 line(s) of comment
*****
* AREA 101 *
*****
4 CATCHMENT
101.000 ID No.ó 99999
.269 Area in hectares
20.000 Length (PERV) metres
2.000 Gradient (%)
4.000 Per cent Impervious
20.000 Length (IMPERV)
.000 %Imp. with Zero Dpth
1 Option 1=SCS CN/C; 2=Horton; 3=Green-Ampt; 4=Repeat
.250 Manning "n"
71.000 SCS Curve No or C
.100 Ia/S Coefficient
10.375 Initial Abstraction
1 Option 1=Trianglr; 2=Rectanglr; 3=SWM HYD; 4=Lin. Reserv
.047 .000 .546 .546 c.m/s
.393 .922 .415 C perv/imperv/total
15 ADD RUNOFF
.047 .047 .546 .546 c.m/s
35 COMMENT
3 line(s) of comment
*****
* AREA 105 *
*****
4 CATCHMENT
105.000 ID No.ó 99999
.533 Area in hectares
20.000 Length (PERV) metres
4.000 Gradient (%)
.000 Per cent Impervious
20.000 Length (IMPERV)
.000 %Imp. with Zero Dpth
1 Option 1=SCS CN/C; 2=Horton; 3=Green-Ampt; 4=Repeat
.250 Manning "n"

```

```

71.000    SCS Curve No or C
.100      Ia/S Coefficient
10.375    Initial Abstraction
  1       Option 1=Trianglr; 2=Rectanglr; 3=SWM HYD; 4=Lin. Reserv
        .098      .047      .546      .546 c.m/s
        .394      .000      .394      C perv/imperv/total
15  ADD RUNOFF
        .098      .145      .546      .546 c.m/s
  9  ROUTE
        .000      Conduit Length
        .000      No Conduit defined
        .000      Zero lag
        .000      Beta weighting factor
        .000      Routing timestep
        0       No. of sub-reaches
        .098      .145      .145      .546 c.m/s
17  COMBINE
600      Junction Node No.
        .098      .145      .145      .668 c.m/s
14  START
  1       1=Zero; 2=Define
35  COMMENT
  3       line(s) of comment
        *****
        * AREA 106 *
        *****
  4  CATCHMENT
106.000   ID No.ó 99999
        .147      Area in hectares
20.000   Length (PERV) metres
4.000    Gradient (%)
.000     Per cent Impervious
20.000   Length (IMPERV)
.000     %Imp. with Zero Dpth
  1       Option 1=SCS CN/C; 2=Horton; 3=Green-Ampt; 4=Repeat
        .250      Manning "n"
71.000   SCS Curve No or C
.100     Ia/S Coefficient
10.375   Initial Abstraction
  1       Option 1=Trianglr; 2=Rectanglr; 3=SWM HYD; 4=Lin. Reserv
        .027      .000      .145      .668 c.m/s
        .394      .000      .394      C perv/imperv/total
15  ADD RUNOFF
        .027      .027      .145      .668 c.m/s
  9  ROUTE
        .000      Conduit Length
        .000      No Conduit defined
        .000      Zero lag
        .000      Beta weighting factor
        .000      Routing timestep
        0       No. of sub-reaches
        .027      .027      .027      .668 c.m/s
17  COMBINE
600      Junction Node No.
        .027      .027      .027      .692 c.m/s
35  COMMENT
  3       line(s) of comment
        *****
        * PEAK FLOW TO EAST *
        *****
18  CONFLUENCE
600      Junction Node No.
        .027      .692      .027      .000 c.m/s
14  START
  1       1=Zero; 2=Define
35  COMMENT

```

```

3   line(s) of comment
*****
* PROPOSED CONDITIONS *
*****
35  COMMENT
3   line(s) of comment
*****
* AREA 202 *
*****
4   CATCHMENT
202.000  ID No.6 99999
      .337  Area in hectares
20.000   Length (PERV) metres
4.000    Gradient (%)
      .000  Per cent Impervious
20.000   Length (IMPERV)
      .000  %Imp. with Zero Dpth
      1    Option 1=SCS CN/C; 2=Horton; 3=Green-Ampt; 4=Repeat
      .250  Manning "n"
71.000   SCS Curve No or C
      .100  Ia/S Coefficient
10.375   Initial Abstraction
      1    Option 1=Trianglr; 2=Rectanglr; 3=SWM HYD; 4=Lin. Reserv
          .062   .000   .027   .000 c.m/s
          .394   .000   .394   C perv/imperv/total
35  COMMENT
3   line(s) of comment
*****
* PEAK FLOW TO WEST *
*****
15  ADD RUNOFF
      .062   .062   .027   .000 c.m/s
14  START
1   1=Zero; 2=Define
35  COMMENT
3   line(s) of comment
*****
* AREA 102 *
*****
4   CATCHMENT
102.000  ID No.6 99999
      .928  Area in hectares
30.000   Length (PERV) metres
4.000    Gradient (%)
      .000  Per cent Impervious
30.000   Length (IMPERV)
      .000  %Imp. with Zero Dpth
      1    Option 1=SCS CN/C; 2=Horton; 3=Green-Ampt; 4=Repeat
      .250  Manning "n"
71.000   SCS Curve No or C
      .100  Ia/S Coefficient
10.375   Initial Abstraction
      1    Option 1=Trianglr; 2=Rectanglr; 3=SWM HYD; 4=Lin. Reserv
          .155   .000   .027   .000 c.m/s
          .394   .000   .394   C perv/imperv/total
15  ADD RUNOFF
      .155   .155   .027   .000 c.m/s
35  COMMENT
3   line(s) of comment
*****
* AREA 203 *
*****
4   CATCHMENT
203.000  ID No.6 99999
      .648  Area in hectares
20.000   Length (PERV) metres

```

```

4.000 Gradient (%)
.000 Per cent Impervious
20.000 Length (IMPERV)
.000 %Imp. with Zero Dpth
1 Option 1=SCS CN/C; 2=Horton; 3=Green-Ampt; 4=Repeat
.250 Manning "n"
71.000 SCS Curve No or C
.100 Ia/S Coefficient
10.375 Initial Abstraction
1 Option 1=Trianglr; 2=Rectanglr; 3=SWM HYD; 4=Lin. Reserv
.119 .155 .027 .000 c.m/s
.394 .000 .394 C perv/imperv/total
15 ADD RUNOFF
.119 .274 .027 .000 c.m/s
35 COMMENT
3 line(s) of comment
*****
* AREA 103 *
*****
4 CATCHMENT
103.000 ID No.ó 99999
.069 Area in hectares
10.000 Length (PERV) metres
2.000 Gradient (%)
72.000 Per cent Impervious
10.000 Length (IMPERV)
.000 %Imp. with Zero Dpth
1 Option 1=SCS CN/C; 2=Horton; 3=Green-Ampt; 4=Repeat
.250 Manning "n"
71.000 SCS Curve No or C
.100 Ia/S Coefficient
10.375 Initial Abstraction
1 Option 1=Trianglr; 2=Rectanglr; 3=SWM HYD; 4=Lin. Reserv
.027 .274 .027 .000 c.m/s
.391 .892 .752 C perv/imperv/total
15 ADD RUNOFF
.027 .289 .027 .000 c.m/s
9 ROUTE
.000 Conduit Length
.000 No Conduit defined
.000 Zero lag
.000 Beta weighting factor
.000 Routing timestep
0 No. of sub-reaches
.027 .289 .289 .000 c.m/s
17 COMBINE
700 Junction Node No.
.027 .289 .289 .289 c.m/s
14 START
1 1=Zero; 2=Define
35 COMMENT
3 line(s) of comment
*****
* AREA 201 *
*****
4 CATCHMENT
201.000 ID No.ó 99999
2.110 Area in hectares
20.000 Length (PERV) metres
4.000 Gradient (%)
50.000 Per cent Impervious
20.000 Length (IMPERV)
.000 %Imp. with Zero Dpth
1 Option 1=SCS CN/C; 2=Horton; 3=Green-Ampt; 4=Repeat
.250 Manning "n"
71.000 SCS Curve No or C

```

```

.100    Ia/S Coefficient
10.375  Initial Abstraction
  1     Option 1=Trianglr; 2=Rectanglr; 3=SWM HYD; 4=Lin. Reserv
      .606    .000    .289    .289 c.m/s
      .394    .909    .651    C perv/imperv/total
15  ADD RUNOFF
      .606    .606    .289    .289 c.m/s
35  COMMENT
  3     line(s) of comment
      *****
      * AREA 204 *
      *****
  4     CATCHMENT
204.000 ID No.ó 99999
  .145  Area in hectares
10.000  Length (PERV) metres
  2.000  Gradient (%)
10.000  Per cent Impervious
10.000  Length (IMPERV)
  .000  %Imp. with Zero Dpth
  1     Option 1=SCS CN/C; 2=Horton; 3=Green-Ampt; 4=Repeat
  .250  Manning "n"
71.000  SCS Curve No or C
  .100  Ia/S Coefficient
10.375  Initial Abstraction
  1     Option 1=Trianglr; 2=Rectanglr; 3=SWM HYD; 4=Lin. Reserv
      .029    .606    .289    .289 c.m/s
      .391    .892    .441    C perv/imperv/total
15  ADD RUNOFF
      .029    .624    .289    .289 c.m/s
35  COMMENT
  3     line(s) of comment
      *****
      * UNDERGROUND STORAGE *
      *****
10  POND
11  Depth - Discharge - Volume sets
      .000    .000    .0
      .100    .0295    65.0
      .200    .0313    130.9
      .300    .0458    195.0
      .400    .0567    260.0
      .500    .0658    325.0
      .600    .0738    390.0
      .700    .0809    455.0
      .800    .0876    520.0
      .900    .195    585.0
      1.000    .386    650.0
      Peak Outflow = .311 c.m/s
      Maximum Depth = .961 metres
      Maximum Storage = 624. c.m
      .029    .624    .311    .289 c.m/s
17  COMBINE
700  Junction Node No.
      .029    .624    .311    .564 c.m/s
14  START
  1     1=Zero; 2=Define
35  COMMENT
  3     line(s) of comment
      *****
      * AREA 101 *
      *****
  4     CATCHMENT
101.000 ID No.ó 99999
  .269  Area in hectares
20.000  Length (PERV) metres

```

```

2.000 Gradient (%)
4.000 Per cent Impervious
20.000 Length (IMPERV)
.000 %Imp. with Zero Dpth
1 Option 1=SCS CN/C; 2=Horton; 3=Green-Ampt; 4=Repeat
.250 Manning "n"
71.000 SCS Curve No or C
.100 Ia/S Coefficient
10.375 Initial Abstraction
1 Option 1=Trianglr; 2=Rectanglr; 3=SWM HYD; 4=Lin. Reserv
.047 .000 .311 .564 c.m/s
.393 .922 .415 C perv/imperv/total
15 ADD RUNOFF
.047 .047 .311 .564 c.m/s
35 COMMENT
3 line(s) of comment
*****
* AREA 205 *
*****
4 CATCHMENT
205.000 ID No.ó 99999
.368 Area in hectares
10.000 Length (PERV) metres
10.000 Gradient (%)
.000 Per cent Impervious
10.000 Length (IMPERV)
.000 %Imp. with Zero Dpth
1 Option 1=SCS CN/C; 2=Horton; 3=Green-Ampt; 4=Repeat
.250 Manning "n"
71.000 SCS Curve No or C
.100 Ia/S Coefficient
10.375 Initial Abstraction
1 Option 1=Trianglr; 2=Rectanglr; 3=SWM HYD; 4=Lin. Reserv
.077 .047 .311 .564 c.m/s
.390 .000 .390 C perv/imperv/total
15 ADD RUNOFF
.077 .116 .311 .564 c.m/s
9 ROUTE
.000 Conduit Length
.000 No Conduit defined
.000 Zero lag
.000 Beta weighting factor
.000 Routing timestep
0 No. of sub-reaches
.077 .116 .116 .564 c.m/s
17 COMBINE
700 Junction Node No.
.077 .116 .116 .649 c.m/s
35 COMMENT
3 line(s) of comment
*****
* PEAK FLOW TO EAST *
*****
18 CONFLUENCE
700 Junction Node No.
.077 .649 .116 .000 c.m/s
20 MANUAL

```

Output File (4.7) 111618R2.OUT opened 2021-12-22 10:34

Units used are defined by G = 9.810

72 500 10.000 are MAXDT MAXHYD & DTMIN values

Licensee: PLANNING INITIATIVES LTD

35 COMMENT

6 line(s) of comment

 * 111618 - OSPRINGE DEVELOPMENT *
 * COUNTY OF WELLINGTON *
 * IBI GROUP *
 * JANUARY 2018 - REVISED DECEMBER 2021 *

35 COMMENT

4 line(s) of comment

 * REGIONAL STORM-FINAL 12 HOURS *
 * AMC III *

2 STORM

3 1=Chicago;2=Huff;3=User;4=Cdn1hr;5=Historic

212.000 Total depth of Rain

720.000 Duration ó 720 min

User storm is HAZEL12h

6.360	6.360	6.360	6.360	6.360
6.360	4.240	4.240	4.240	4.240
4.240	4.240	6.360	6.360	6.360
6.360	6.360	6.360	12.720	12.720
12.720	12.720	12.720	12.720	16.960
16.960	16.960	16.960	16.960	16.960
12.720	12.720	12.720	12.720	12.720
12.720	23.320	23.320	23.320	23.320
23.320	23.320	12.720	12.720	12.720
12.720	12.720	12.720	12.720	12.720
12.720	12.720	12.720	12.720	53.000
53.000	53.000	53.000	53.000	53.000
38.160	38.160	38.160	38.160	38.160
38.160	12.720	12.720	12.720	12.720
12.720	12.720			

212.000 mm Total depth

3 IMPERVIOUS

1 Option 1=SCS CN/C; 2=Horton; 3=Green-Ampt; 4=Repeat
 .013 Manning "n"
 98.000 SCS Curve No or C
 .100 Ia/S Coefficient
 .518 Initial Abstraction

35 COMMENT

3 line(s) of comment

 * EXISTING CONDITIONS *

35 COMMENT

3 line(s) of comment

 * AREA 104 *

4 CATCHMENT

104.000 ID No.ó 99999
 .382 Area in hectares
 20.000 Length (PERV) metres
 4.000 Gradient (%)
 .000 Per cent Impervious
 20.000 Length (IMPERV)
 .000 %Imp. with Zero Dpth
 1 Option 1=SCS CN/C; 2=Horton; 3=Green-Ampt; 4=Repeat
 .250 Manning "n"
 84.000 SCS Curve No or C

```

.100    Ia/S Coefficient
4.838    Initial Abstraction
    1    Option 1=Trianglr; 2=Rectanglr; 3=SWM HYD; 4=Lin. Reserv
        .053    .000    .000    .000 c.m/s
        .788    .000    .788    C perv/imperv/total
35  COMMENT
    3    line(s) of comment
    *****
    * PEAK FLOW TO WEST *
    *****
15  ADD RUNOFF
        .053    .053    .000    .000 c.m/s
14  START
    1    1=Zero; 2=Define
35  COMMENT
    3    line(s) of comment
    *****
    * AREA 102 *
    *****
4  CATCHMENT
102.000  ID No.ó 99999
    .928    Area in hectares
30.000  Length (PERV) metres
4.000  Gradient (%)
    .000  Per cent Impervious
30.000  Length (IMPERV)
    .000  %Imp. with Zero Dpth
    1    Option 1=SCS CN/C; 2=Horton; 3=Green-Ampt; 4=Repeat
    .250  Manning "n"
84.000  SCS Curve No or C
    .100  Ia/S Coefficient
4.838  Initial Abstraction
    1    Option 1=Trianglr; 2=Rectanglr; 3=SWM HYD; 4=Lin. Reserv
        .130    .000    .000    .000 c.m/s
        .783    .000    .783    C perv/imperv/total
15  ADD RUNOFF
        .130    .130    .000    .000 c.m/s
9  ROUTE
    .000  Conduit Length
    .000  No Conduit defined
    .000  Zero lag
    .000  Beta weighting factor
    .000  Routing timestep
    0    No. of sub-reaches
        .130    .130    .130    .000 c.m/s
17  COMBINE
500  Junction Node No.
        .130    .130    .130    .130 c.m/s
14  START
    1    1=Zero; 2=Define
35  COMMENT
    3    line(s) of comment
    *****
    * AREA 103 *
    *****
4  CATCHMENT
103.000  ID No.ó 99999
    .069  Area in hectares
10.000  Length (PERV) metres
2.000  Gradient (%)
72.000  Per cent Impervious
10.000  Length (IMPERV)
    .000  %Imp. with Zero Dpth
    1    Option 1=SCS CN/C; 2=Horton; 3=Green-Ampt; 4=Repeat
    .250  Manning "n"
84.000  SCS Curve No or C

```

```

.100    Ia/S Coefficient
4.838   Initial Abstraction
  1     Option 1=Trianglr; 2=Rectanglr; 3=SWM HYD; 4=Lin. Reserv
      .009    .000    .130    .130 c.m/s
      .781    .894    .862    C perv/imperv/total
15  ADD RUNOFF
      .009    .009    .130    .130 c.m/s
  9  ROUTE
      .000    Conduit Length
      .000    No Conduit defined
      .000    Zero lag
      .000    Beta weighting factor
      .000    Routing timestep
      0     No. of sub-reaches
      .009    .009    .009    .130 c.m/s
17  COMBINE
500    Junction Node No.
      .009    .009    .009    .139 c.m/s
18  CONFLUENCE
500    Junction Node No.
      .009    .139    .009    .000 c.m/s
35  COMMENT
  3    line(s) of comment
      *****
      * AREA 107 *
      *****
  4  CATCHMENT
107.000 ID No.ó 99999
  2.560 Area in hectares
  50.000 Length (PERV) metres
  4.000 Gradient (%)
  1.000 Per cent Impervious
  50.000 Length (IMPERV)
  .000 %Imp. with Zero Dpth
  1     Option 1=SCS CN/C; 2=Horton; 3=Green-Ampt; 4=Repeat
  .250 Manning "n"
  84.000 SCS Curve No or C
  .100 Ia/S Coefficient
  4.838 Initial Abstraction
  1     Option 1=Trianglr; 2=Rectanglr; 3=SWM HYD; 4=Lin. Reserv
      .364    .139    .009    .000 c.m/s
      .786    .962    .788    C perv/imperv/total
15  ADD RUNOFF
      .364    .498    .009    .000 c.m/s
  9  ROUTE
      .000    Conduit Length
      .000    No Conduit defined
      .000    Zero lag
      .000    Beta weighting factor
      .000    Routing timestep
      0     No. of sub-reaches
      .364    .498    .498    .000 c.m/s
17  COMBINE
600    Junction Node No.
      .364    .498    .498    .498 c.m/s
14  START
  1     1=Zero; 2=Define
35  COMMENT
  3    line(s) of comment
      *****
      * AREA 101 *
      *****
  4  CATCHMENT
101.000 ID No.ó 99999
  .269 Area in hectares
  20.000 Length (PERV) metres

```

```

2.000 Gradient (%)
4.000 Per cent Impervious
20.000 Length (IMPERV)
.000 %Imp. with Zero Dpth
1 Option 1=SCS CN/C; 2=Horton; 3=Green-Ampt; 4=Repeat
.250 Manning "n"
84.000 SCS Curve No or C
.100 Ia/S Coefficient
4.838 Initial Abstraction
1 Option 1=Trianglr; 2=Rectanglr; 3=SWM HYD; 4=Lin. Reserv
.038 .000 .498 .498 c.m/s
.784 .944 .790 C perv/imperv/total
15 ADD RUNOFF
.038 .038 .498 .498 c.m/s
35 COMMENT
3 line(s) of comment
*****
* AREA 105 *
*****
4 CATCHMENT
105.000 ID No.ó 99999
.533 Area in hectares
20.000 Length (PERV) metres
4.000 Gradient (%)
.000 Per cent Impervious
20.000 Length (IMPERV)
.000 %Imp. with Zero Dpth
1 Option 1=SCS CN/C; 2=Horton; 3=Green-Ampt; 4=Repeat
.250 Manning "n"
84.000 SCS Curve No or C
.100 Ia/S Coefficient
4.838 Initial Abstraction
1 Option 1=Trianglr; 2=Rectanglr; 3=SWM HYD; 4=Lin. Reserv
.074 .038 .498 .498 c.m/s
.788 .000 .788 C perv/imperv/total
15 ADD RUNOFF
.074 .112 .498 .498 c.m/s
9 ROUTE
.000 Conduit Length
.000 No Conduit defined
.000 Zero lag
.000 Beta weighting factor
.000 Routing timestep
0 No. of sub-reaches
.074 .112 .112 .498 c.m/s
17 COMBINE
600 Junction Node No.
.074 .112 .112 .607 c.m/s
14 START
1 1=Zero; 2=Define
35 COMMENT
3 line(s) of comment
*****
* AREA 106 *
*****
4 CATCHMENT
106.000 ID No.ó 99999
.147 Area in hectares
20.000 Length (PERV) metres
4.000 Gradient (%)
.000 Per cent Impervious
20.000 Length (IMPERV)
.000 %Imp. with Zero Dpth
1 Option 1=SCS CN/C; 2=Horton; 3=Green-Ampt; 4=Repeat
.250 Manning "n"
84.000 SCS Curve No or C

```

```

.100    Ia/S Coefficient
4.838   Initial Abstraction
  1     Option 1=Trianglr; 2=Rectanglr; 3=SWM HYD; 4=Lin. Reserv
      .020    .000    .112    .607 c.m/s
      .788    .000    .788    C perv/imperv/total
15  ADD RUNOFF
      .020    .020    .112    .607 c.m/s
  9  ROUTE
      .000    Conduit Length
      .000    No Conduit defined
      .000    Zero lag
      .000    Beta weighting factor
      .000    Routing timestep
      0     No. of sub-reaches
      .020    .020    .020    .607 c.m/s
17  COMBINE
600    Junction Node No.
      .020    .020    .020    .627 c.m/s
35  COMMENT
  3     line(s) of comment
      *****
      * PEAK FLOW TO EAST *
      *****
18  CONFLUENCE
600    Junction Node No.
      .020    .627    .020    .000 c.m/s
14  START
  1     1=Zero; 2=Define
35  COMMENT
  3     line(s) of comment
      *****
      * PROPOSED CONDITIONS *
      *****
35  COMMENT
  3     line(s) of comment
      *****
      * AREA 202 *
      *****
  4  CATCHMENT
202.000 ID No.6 99999
   .337 Area in hectares
20.000 Length (PERV) metres
  4.000 Gradient (%)
   .000 Per cent Impervious
20.000 Length (IMPERV)
   .000 %Imp. with Zero Dpth
      1     Option 1=SCS CN/C; 2=Horton; 3=Green-Ampt; 4=Repeat
      .250 Manning "n"
84.000 SCS Curve No or C
   .100 Ia/S Coefficient
4.838   Initial Abstraction
  1     Option 1=Trianglr; 2=Rectanglr; 3=SWM HYD; 4=Lin. Reserv
      .047    .000    .020    .000 c.m/s
      .788    .000    .788    C perv/imperv/total
35  COMMENT
  3     line(s) of comment
      *****
      * PEAK FLOW TO WEST *
      *****
15  ADD RUNOFF
      .047    .047    .020    .000 c.m/s
14  START
  1     1=Zero; 2=Define
35  COMMENT
  3     line(s) of comment
      *****

```

* AREA 102 *

4 CATCHMENT
 102.000 ID No.ó 99999
 .928 Area in hectares
 30.000 Length (PERV) metres
 4.000 Gradient (%)
 .000 Per cent Impervious
 30.000 Length (IMPERV)
 .000 %Imp. with Zero Dpth
 1 Option 1=SCS CN/C; 2=Horton; 3=Green-Ampt; 4=Repeat
 .250 Manning "n"
 84.000 SCS Curve No or C
 .100 Ia/S Coefficient
 4.838 Initial Abstraction
 1 Option 1=Trianglr; 2=Rectanglr; 3=SWM HYD; 4=Lin. Reserv
 .130 .000 .020 .000 c.m/s
 .783 .000 .783 C perv/imperv/total
 15 ADD RUNOFF
 .130 .130 .020 .000 c.m/s

35 COMMENT
 3 line(s) of comment

 * AREA 203 *

4 CATCHMENT
 203.000 ID No.ó 99999
 .648 Area in hectares
 20.000 Length (PERV) metres
 4.000 Gradient (%)
 .000 Per cent Impervious
 20.000 Length (IMPERV)
 .000 %Imp. with Zero Dpth
 1 Option 1=SCS CN/C; 2=Horton; 3=Green-Ampt; 4=Repeat
 .250 Manning "n"
 84.000 SCS Curve No or C
 .100 Ia/S Coefficient
 4.838 Initial Abstraction
 1 Option 1=Trianglr; 2=Rectanglr; 3=SWM HYD; 4=Lin. Reserv
 .090 .130 .020 .000 c.m/s
 .788 .000 .788 C perv/imperv/total
 15 ADD RUNOFF
 .090 .220 .020 .000 c.m/s

35 COMMENT
 3 line(s) of comment

 * AREA 103 *

4 CATCHMENT
 103.000 ID No.ó 99999
 .069 Area in hectares
 10.000 Length (PERV) metres
 2.000 Gradient (%)
 72.000 Per cent Impervious
 10.000 Length (IMPERV)
 .000 %Imp. with Zero Dpth
 1 Option 1=SCS CN/C; 2=Horton; 3=Green-Ampt; 4=Repeat
 .250 Manning "n"
 84.000 SCS Curve No or C
 .100 Ia/S Coefficient
 4.838 Initial Abstraction
 1 Option 1=Trianglr; 2=Rectanglr; 3=SWM HYD; 4=Lin. Reserv
 .009 .220 .020 .000 c.m/s
 .781 .894 .862 C perv/imperv/total
 15 ADD RUNOFF
 .009 .229 .020 .000 c.m/s

```

9  ROUTE
   .000  Conduit Length
   .000  No Conduit defined
   .000  Zero lag
   .000  Beta weighting factor
   .000  Routing timestep
     0    No. of sub-reaches
       .009  .229  .229  .000 c.m/s
17  COMBINE
700  Junction Node No.
     .009  .229  .229  .229 c.m/s
14  START
1    1=Zero; 2=Define
35  COMMENT
3    line(s) of comment
     *****
     * AREA 201 *
     *****
4  CATCHMENT
201.000  ID No.6 99999
   2.110  Area in hectares
20.000  Length (PERV) metres
4.000  Gradient (%)
50.000  Per cent Impervious
20.000  Length (IMPERV)
   .000  %Imp. with Zero Dpth
     1    Option 1=SCS CN/C; 2=Horton; 3=Green-Ampt; 4=Repeat
     .250  Manning "n"
84.000  SCS Curve No or C
   .100  Ia/S Coefficient
4.838  Initial Abstraction
     1    Option 1=Trianglr; 2=Rectanglr; 3=SWM HYD; 4=Lin. Reserv
       .287  .000  .229  .229 c.m/s
       .788  .922  .855  C perv/imperv/total
15  ADD RUNOFF
     .287  .287  .229  .229 c.m/s
35  COMMENT
3    line(s) of comment
     *****
     * AREA 204 *
     *****
4  CATCHMENT
204.000  ID No.6 99999
   .145  Area in hectares
10.000  Length (PERV) metres
2.000  Gradient (%)
10.000  Per cent Impervious
10.000  Length (IMPERV)
   .000  %Imp. with Zero Dpth
     1    Option 1=SCS CN/C; 2=Horton; 3=Green-Ampt; 4=Repeat
     .250  Manning "n"
84.000  SCS Curve No or C
   .100  Ia/S Coefficient
4.838  Initial Abstraction
     1    Option 1=Trianglr; 2=Rectanglr; 3=SWM HYD; 4=Lin. Reserv
       .019  .287  .229  .229 c.m/s
       .781  .894  .792  C perv/imperv/total
15  ADD RUNOFF
     .019  .306  .229  .229 c.m/s
35  COMMENT
3    line(s) of comment
     *****
     * UNDERGROUND STORAGE *
     *****
10  POND
11  Depth - Discharge - Volume sets

```

```

.000      .000      .0
.100      .0295     65.0
.200      .0313     130.9
.300      .0458     195.0
.400      .0567     260.0
.500      .0658     325.0
.600      .0738     390.0
.700      .0809     455.0
.800      .0876     520.0
.900      .195      585.0
1.000     .386      650.0
Peak Outflow = .304 c.m/s
Maximum Depth = .957 metres
Maximum Storage = 622. c.m
.019      .306      .304      .229 c.m/s
17  COMBINE
700  Junction Node No.
.019      .306      .304      .528 c.m/s
14  START
1     1=Zero; 2=Define
35  COMMENT
3     line(s) of comment
*****
* AREA 101 *
*****
4  CATCHMENT
101.000  ID No.ó 99999
.269    Area in hectares
20.000  Length (PERV) metres
2.000   Gradient (%)
4.000   Per cent Impervious
20.000  Length (IMPERV)
.000    %Imp. with Zero Dpth
1       Option 1=SCS CN/C; 2=Horton; 3=Green-Ampt; 4=Repeat
.250    Manning "n"
84.000  SCS Curve No or C
.100    Ia/S Coefficient
4.838   Initial Abstraction
1       Option 1=Trianglr; 2=Rectanglr; 3=SWM HYD; 4=Lin. Reserv
.038    .000      .304      .528 c.m/s
.784    .944      .790      C perv/imperv/total
15  ADD RUNOFF
.038    .038      .304      .528 c.m/s
35  COMMENT
3     line(s) of comment
*****
* AREA 205 *
*****
4  CATCHMENT
205.000  ID No.ó 99999
.368    Area in hectares
10.000  Length (PERV) metres
10.000  Gradient (%)
.000    Per cent Impervious
10.000  Length (IMPERV)
.000    %Imp. with Zero Dpth
1       Option 1=SCS CN/C; 2=Horton; 3=Green-Ampt; 4=Repeat
.250    Manning "n"
84.000  SCS Curve No or C
.100    Ia/S Coefficient
4.838   Initial Abstraction
1       Option 1=Trianglr; 2=Rectanglr; 3=SWM HYD; 4=Lin. Reserv
.051    .038      .304      .528 c.m/s
.779    .000      .779      C perv/imperv/total
15  ADD RUNOFF
.051    .087      .304      .528 c.m/s

```

```

9  ROUTE
   .000  Conduit Length
   .000  No Conduit defined
   .000  Zero lag
   .000  Beta weighting factor
   .000  Routing timestep
   0     No. of sub-reaches
       .051      .087      .087      .528 c.m/s
17  COMBINE
   700  Junction Node No.
       .051      .087      .087      .615 c.m/s
35  COMMENT
   3    line(s) of comment
   *****
   * PEAK FLOW TO EAST *
   *****
18  CONFLUENCE
   700  Junction Node No.
       .051      .615      .087      .000 c.m/s
20  MANUAL

```