



# County of Wellington

## Engineering Services - Roads Division

### Entrance Policy

The safe use of County roads requires control of the construction of entrances onto County roads. The following policy governs as a guideline to control the safety and efficiency of access onto County roads.

The County Roads Division shall consider the following criteria when reviewing all applications for new entrances or alterations to entrances:

- a) All entrances onto County roads shall be under the control of the County Road Division. New installations and alterations shall conform to this policy and be completed according to standards. All costs shall be borne by the owners.
- b) Protection of the public through the orderly control of traffic movements onto and from County roads, including possible requirements for left and/or right turn lanes.
- c) Maintenance of the traffic carrying capacity of the County road network.
- d) Protection of the public investment in County road facilities.
- e) Minimizing County expenditures on maintenance of private entranceways.
- f) Providing legal access onto County roads from adjacent private property.

#### **ENTRANCE PERMITS ARE REQUIRED FOR:**

- Construction of a new entrance
- Changing the design of an existing entrance
- Changing the location of an entrance
- Changing the use of an entrance (i.e. the Classification)
- Construction of a temporary entrance
- Paving of an existing entrance

#### **ENTRANCE CLASSIFICATIONS**

**Field Entrance** – Provide access to agricultural fields.

**Farm Entrance** – Provides access to farm buildings and agricultural lands.

**Residential Entrance** – Provide access to residential facilities of four units or less.

**Commercial/Industrial/Institutional Entrance** – Provides access to a business where goods or services are manufactured or sold to the public and includes residential facilities of five or more units.

**Re-Classification Entrance** – When an existing entrance is to be used for other than its intended use (i.e. a field entrance to be used as a residential entrance) will be required to be Re-Classified and to be upgraded to meet current County standards.

**Temporary Entrance** – Provide access to properties for a limited period not to exceed one year for the purpose of construction, repairs or improvement on that property or to facilitate a staged development.

**Emergency Access** – Provide access to subdivision, commercial, industrial developments for emergency vehicles ONLY, in the event that the main access to the development is not passable as requested by the Township/Town emergency services. Adequate measures are to be incorporated in the emergency access to prevent (adequately discourage) use by private residents, delivery vehicles or pedestrians.

**Public Entrance** – Provide access onto a County road from a registered subdivision by means of a public road or street.

**Alteration** – When the resident proposes changes to their existing entrance i.e. to be widened and/or existing surface to be up-graded (i.e. gravel to hot mix asphalt).

## **LOCATION OF ACCESES**

The proposed access location is to be clearly illustrated on a sketch which is to accompany the application for an access permit. The sketch must provide appropriate information to enable staff to locate it in the field, i.e. dimensions to buildings and/or landmarks like fences, hedgerows and tree lines, etc.

The County may restrict the placement of an access onto the County road in the interest of public safety. New accesses must be located as to provide, in the opinion of the County Engineer:

- a) No undue interference with the safe movement of public traffic, pedestrians, or other users of the highway.
- b) Favourable vision, grade and alignment conditions for all traffic using the proposed access to the County road.

Entrances **will not be permitted** at the following locations:

- a) Where access can reasonably be gained via a Town, Village or Township right-of-way.

- b) Along a lane which is identified for the purpose of an exclusive vehicular turning movement.
- c) In close proximity to intersections and bridges.
- d) No access will be permitted on truck climbing, acceleration or deceleration lanes.
- e) Where the following minimum sight distance requirements are not met:

| <b>Posted Speed<br/>(km/hr)</b> | <b>Minimum Sight<br/>Distance (m)</b> |
|---------------------------------|---------------------------------------|
| 50                              | 135                                   |
| 60                              | 165                                   |
| 70                              | 180                                   |
| 80                              | 200                                   |
| 90                              | 210                                   |

Sight distance shall be measured from eye height of 1.05 metres measured 3.0 metres from outer edge of the traffic lane to an object height of 1.3 metres above the roadway surface. **(See Figures 1 and 2).**

An entrance adjacent to a bridge or other structure which may interfere with the clear vision of traffic using the entrance must be located as follows:

- a) A Commercial entrance in an area where the speed limit is 80 km/hr or more must be located at least 145 metres (475 ft) from the end of the deck of the bridge or from the nearest part of the structure which actually interferes with the clear vision of traffic using that entrance.
- b) A Residential, Farm or Field entrance in an area where the speed limit is 80 km/hr or more must be located at least 30 metres (100 ft) from the end of the deck of the bridge or from the nearest part of the structure which actually interferes with the clear vision of the traffic using that entrance.

In areas where the speed limit is less than 80 km/hr, the County Engineer may restrict the location of an entrance to that distance from the bridge or other structure which he deems advisable.

### **NUMBER AND WIDTH OF ACCESSES**

It will be the policy of the County Roads Division to:

- a) Limit the width of accesses to discourage the construction of entrances wider than that required for the safe and reasonable use of the entrance. Typically Residential, Farm or Field entrances will have a maximum width of 6.0 metres and Commercial entrances will have a maximum width of 9.0 metres
- b) Limit the number of accesses to a property to the number required for the safe and reasonable access to the County road and in general conformity with the following:
  - **Residences** - One per property.
  - **Farm Buildings** - One per farm.
  - **Farm Entrance** - Minimum one field entrance per farm with additional field entrances where natural obstructions within the field prevent reasonable access across the field.
  - **Commercial/Industrial Entrances** - Maximum two with a minimum spacing of 30 metres between entrances and/or subject to County official plan.

## **CONSTRUCTION REQUIREMENTS**

### **a) Entrance Grade**

The finished surface of the access must drop away from the edge of the highway driving surface to the end of the shoulder rounding at a rate equal to the slope of the shoulder. For a distance of 5.0 metres beyond the shoulder rounding, the slope of the access is not to exceed 3%.

### **b) Field Entrance**

Shall be surfaced with at least 150 mm (6") crushed gravel or Granular "A" and where a culvert is required, its length must be sufficient to provide a 2:1 slope up from the ditch invert to an entrance width of 6.0 metres. A minimum cover on the culvert is to be 300 mm (12"). (See Figures 3A and 3B).

### **c) Farm or Residential Entrance**

Shall be surfaced with a minimum of 150 mm (6") crushed gravel or Granular 'A'. Where a culvert is required, its length must be sufficient to provide a 2:1 slope up from the ditch invert to an entrance width of 6.0 metres. A minimum cover on the culvert is to be 300 mm (12"). (See Figures 3A and 3B).

### **d) Commercial/Industrial/Institutional Entrance**

Shall be surfaced with hot mix asphalt and where a culvert is required, its length will be dictated by the entrance design which will be site specific, having regard for number and type of vehicles expected to utilize the entrance. Turning lanes and right turn tapers may be required depending on the site traffic requirements. A minimum cover on the culvert is to be 300 mm (12") (See Figure 4A and 4B).

**e) Curbs and/or Headwalls**

No curb or headwall can extend above the surface of the roadway shoulder within the limits of the shoulder and its rounding. All curbs and headwalls are constructed at the sole expense and risk of the applicant.

**f) Culvert**

If a culvert is required, the culvert shall be **new** High Density Polyethylene Pipe (HDPE) double wall or approved equivalent. Used culvert pipe is not acceptable and will be removed at applicant expense. A minimum cover on the culvert is to be 300 mm (12").

**g) Curb and Gutter**

Where curb and gutter exists at the location of the proposed entrance, the applicant will be required to construct a drop curb at the entrance location. The existing curb shall be cut or removed and replaced using materials and construction methods acceptable to the County Engineer.

The area between the curb and sidewalk is to be paved with hot mix asphalt, concrete or paving stones, in accordance with the Engineer's requirements. If there is no sidewalk, the entrance is to be paved a distance of two metres behind the curb.

**h) Temporary/Emergency/Public Entrance**

The design and construction of temporary/emergency and public entrances must be submitted to, and approved, by the County and an access permit issued prior to work commencing on the entrance within the limits of the road allowance of a County road or any works related to said entrance.

**EXISTING ENTRANCES**

All existing entrances having access to a County road which have been legally in existence prior to the release of this standard, are allowed to remain for their present land use unless changes to those entrances are being proposed or required as a result of land use development.

However, the standards outlined in this policy apply:

- a) To all new access connections
- b) When a change in use or upgrade of an existing access (e.g. Farm/Field to Residential) is being carry out.

Where the County has previously issued permits for new or modified entrance the permits will be honoured.

Where the County has endorsed development (e.g. site plan, plan of subdivision, etc.) will be honoured with permits issued as soon as any outstanding requirements have been resolved.

## **MAINTENANCE OF ENTRANCES**

Property owners having access to a County road are fully responsible for the maintenance of the access including the removal of snow and ice and keeping the portion of the access within the right-of-way in a safe condition for vehicular traffic.

Each entrance to a County road must be designed, constructed and maintained in a manner that will prevent surface water from the entrance-way or from the adjoining property being discharged via the entrance onto the travelled portion of the highway.

In the event that County forces are required to perform maintenance to an entranceway, the County will only replace the surface with gravel or hot mix asphalt, as appropriate. The County will not install concrete, brick etc.\*. Maintenance activities may include and not limited to, culvert replacement or construction activities on the County roadway.

\*If the applicant wishes to reinstall concrete or brick etc. the County will pay (after installation) the equivalent of the cost of paving.

## **ADMINSITRATION**

### **a) Permit Fee and Refundable Deposit**

The refundable deposit and permit fee in the following amount shall be collected prior to issuance of the permit. The deposit shall be refunded to the applicant upon acceptance of the entrance by the County Roads Division staff, less any amounts expended to bring the entrance up to County standards.

| Classification of Entrance   | Permit Fee | Refundable Deposit                                       |
|--|------------|--|
| Field, Farm, Residential, Temporary ,<br>Re-Classification, Alteration | \$ 280     | \$ 2000*   |
| Commercial, Industrial, Institutional                                  | \$ 280     | \$ 3,500 min or such<br>as the County may<br>determine * |
| Public, Private, Emergency Road  | \$ 500     | \$ 3,500min or such<br>as the County may<br>determine *  |

\* Deposit will vary depending on foreseeable costs which may be incurred by the County to complete or remove an improper entrance.

### **b) Installation of the Entrance**

The entrance shall be installed by the applicant, at the applicant's expense, to the specifications outline on the permit and in accordance with County standards. In the event an installation does not meet County standard and the applicant refuses to make necessary repairs, the County reserves the right to remove the improper entrance at the applicant's expense.

**c) Compliance of Requirements**

Where and applicant fails to comply with the requirements or provisions of this by-law, the County may recover the expense by requesting that the Treasurer of the local municipality include any part of these fees and charges incurred by the County to the tax roll pursuant to the provisions of section 398 and 446 of the *Municipal Act, 2001*.

**d) Inspection of the Entrance**

The installation of the entrance will be inspected by the County after completion by the applicant and once approved the deposit will be refunded. It shall be the applicant's responsibility to call the County for an inspection of the entrance installation, once it has been completed.

**e) Cancellation of Permit**

Where the entrance has not been constructed and/or not accepted by the County within **one year** of the date of the permit, then the permit shall be canceled and the refundable deposit shall be forfeited.

Where the applicant has decided to withdraw their entrance application, only the refundable deposit will be refunded.

**f) Renewal of Permit**

An entrance permit may be renewed for an additional **six month** period. An application shall be filled out for the renewal and another application fee paid to the County. A second permit will be issued. The deposit fee shall be carried forward to the second permit.

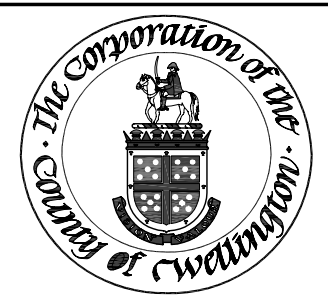
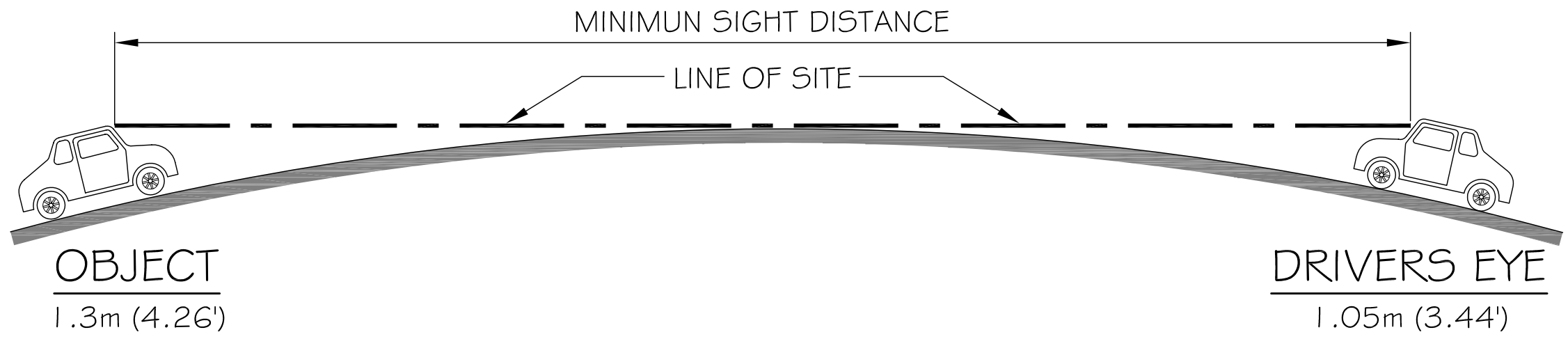
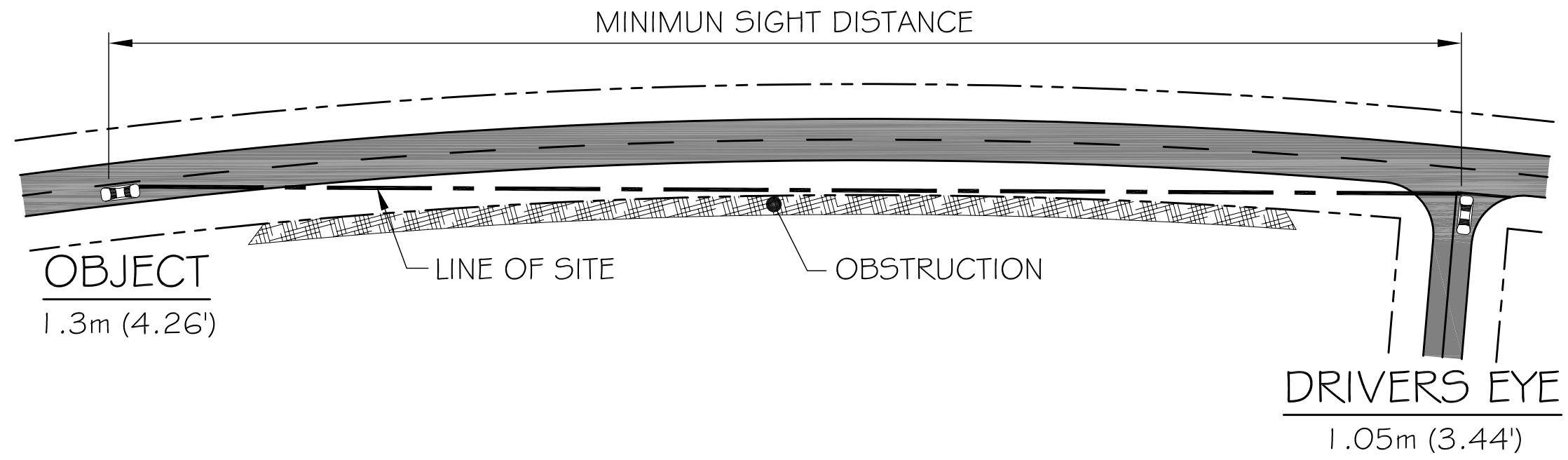

COUNTY OF WELLINGTON STANDARD DRAWING

DATE DRAWN:  
JANUARY 2006

REV. No.:  
R-3

ILLUSTRATION SHOWING  
MINIMUM CLEAR VISION

APPROVED BY:  
-----  
COUNTY ENGINEER

FIGURE - 1





COUNTY OF WELLINGTON STANDARD DRAWING

DATE DRAWN: JANUARY 2006  
REV. No.: R-3

# ILLUSTRATION SHOWING MINIMUM CLEAR VISION

APPROVED BY:

--- COUNTY ENGINEER ---

FIGURE - 2

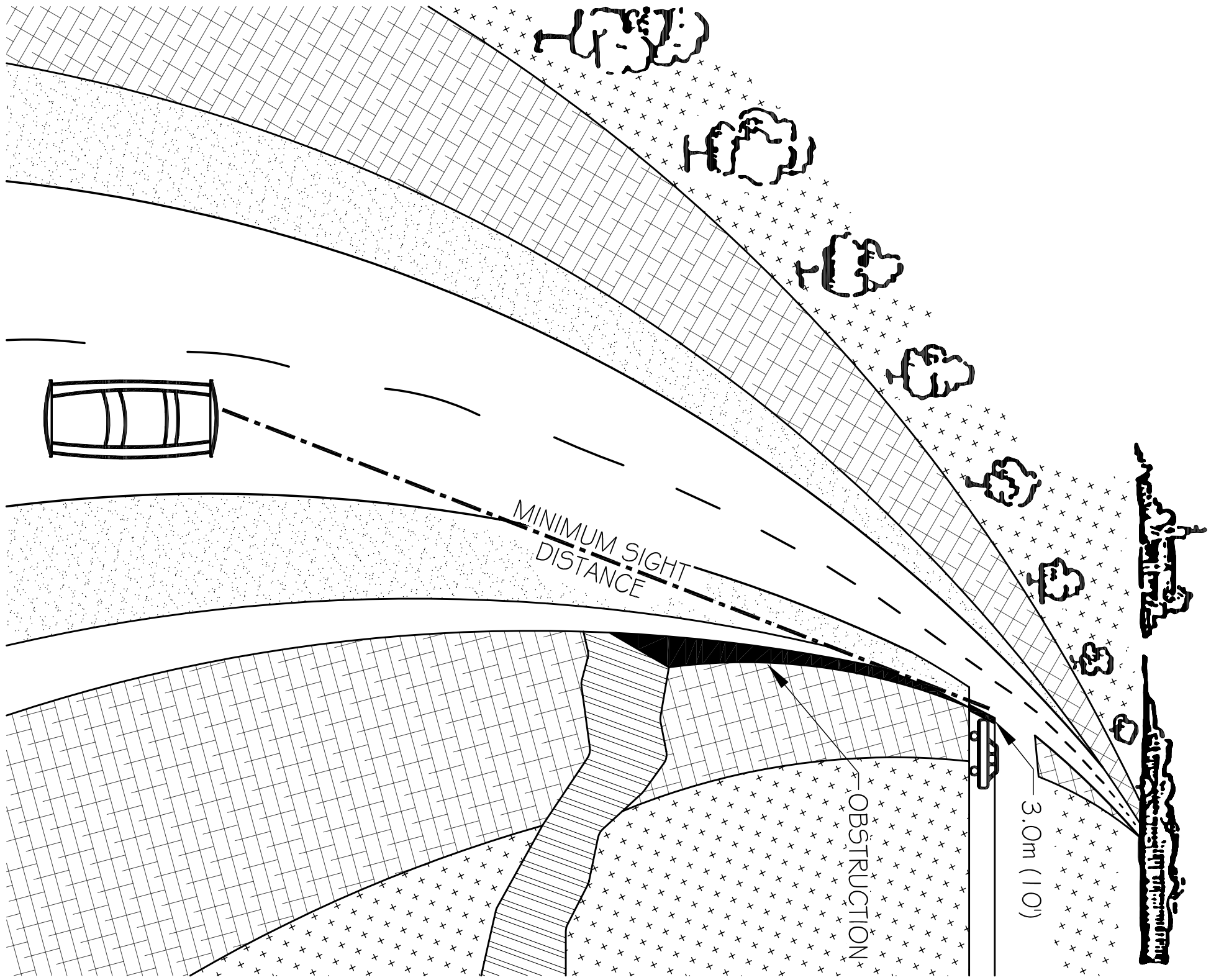

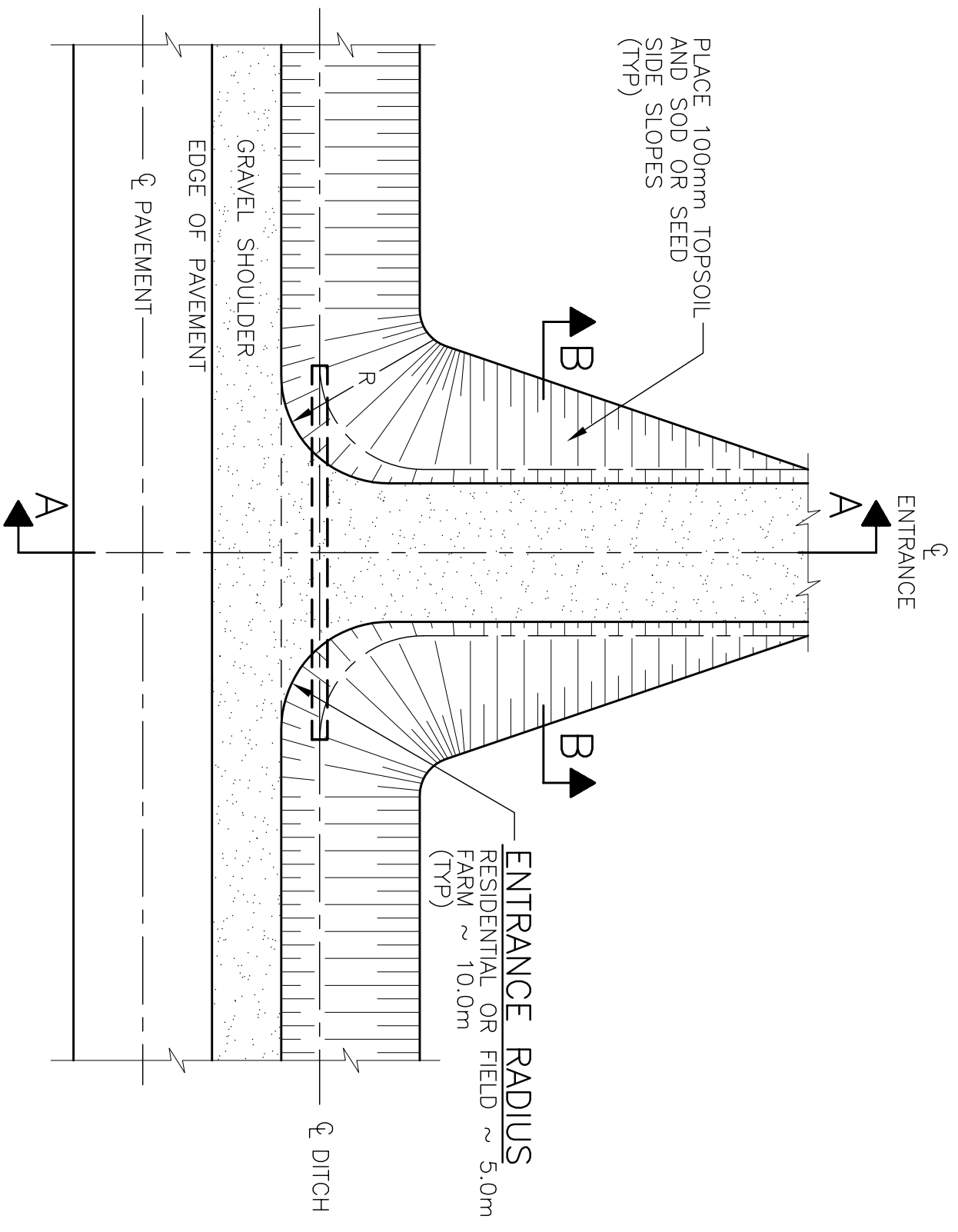

PLAN

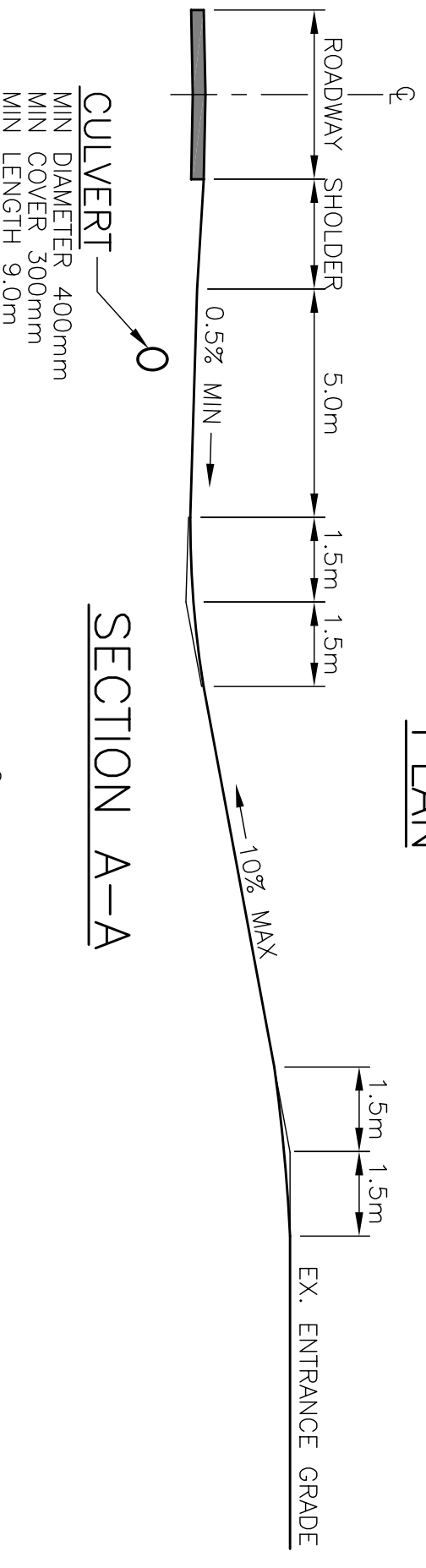

SECTION A-A

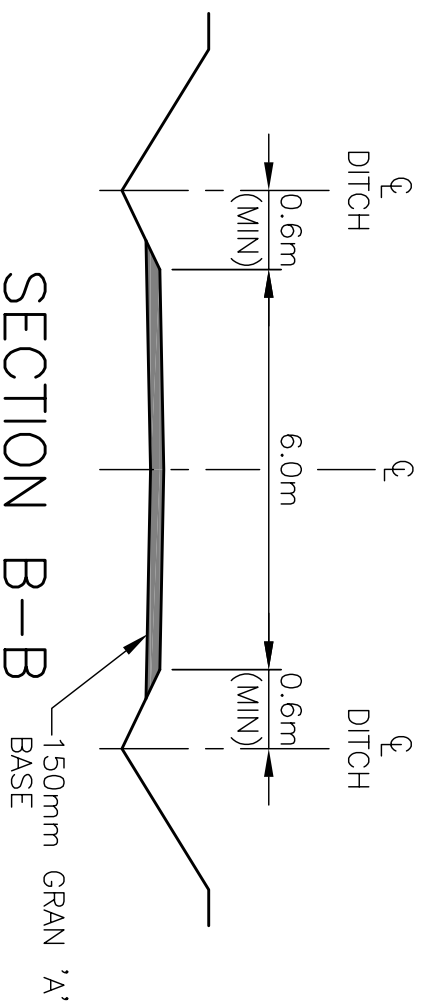

**NOTE:**  
ALL DIMENSIONS ARE IN  
MILLIMETRES OR METRES  
UNLESS OTHERWISE SHOWN.

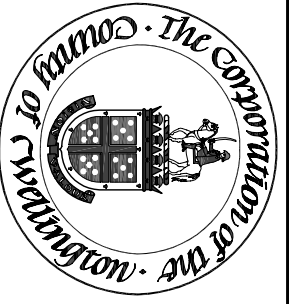

COUNTY OF WELLINGTON STANDARD DRAWING

DATE DRAWN: JANUARY 2006  
REV. No.: R-3  
APPROVED BY:

EARTH CUT ENTRANCE TO  
RESIDENTIAL, FARM OR FIELD

COUNTY ENGINEER

FIGURE - 3A

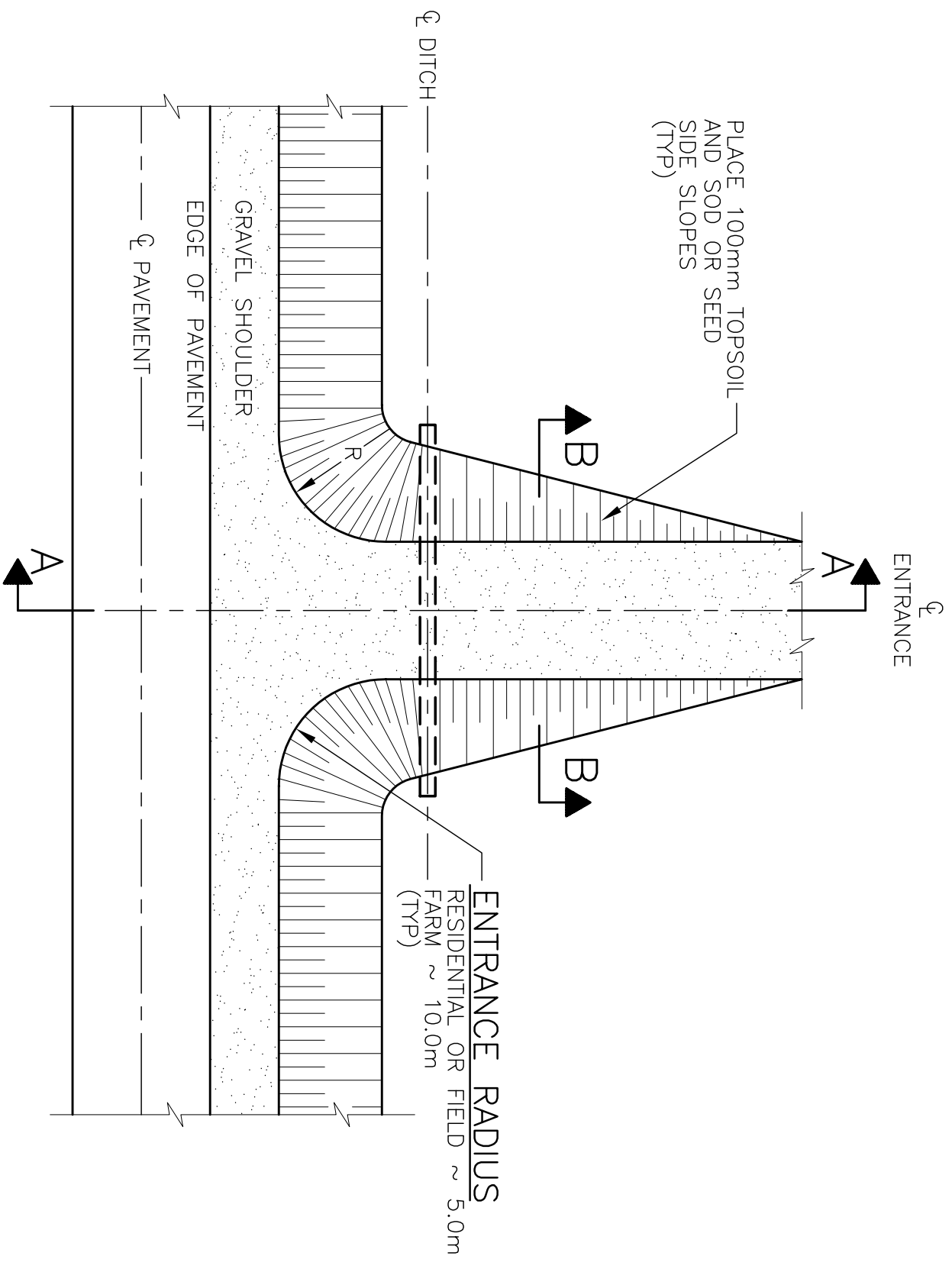

PLAN

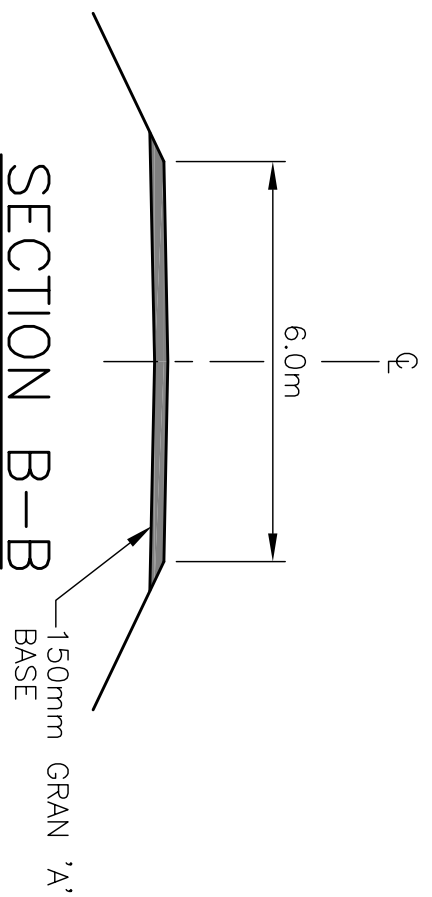
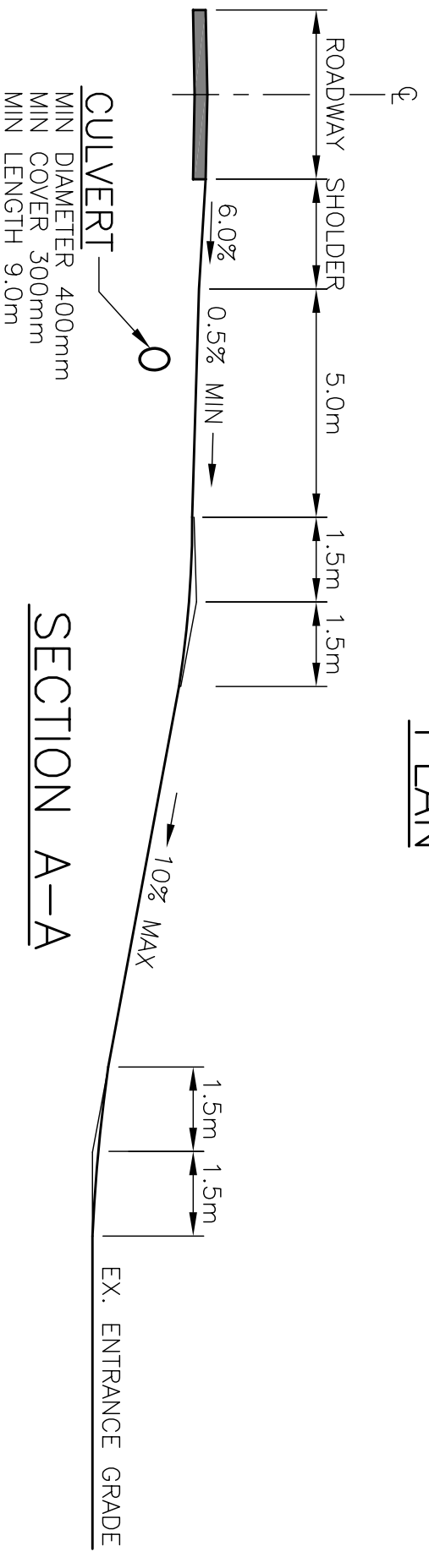

**NOTE:**  
ALL DIMENSIONS ARE IN MILLIMETRES OR METRES UNLESS OTHERWISE SHOWN.

COUNTY OF WELLINGTON STANDARD DRAWING

DATE DRAWN: JANUARY 2006  
REV. No.: R-3

EARTH FILL ENTRANCE TO  
RESIDENTIAL, FARM OR FIELD

COUNTY ENGINEER  
FIGURE - 3B

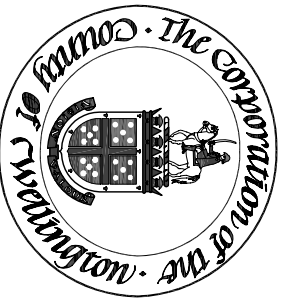

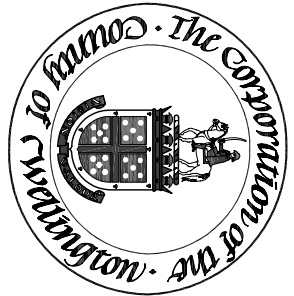

COUNTY OF WELLINGTON STANDARD DRAWING

# EARTH CUT ENTRANCE TO COMMERCIAL, INDUSTRIAL AND INSTITUTIONAL

DATE DRAWN: JANUARY 2006  
 REV. No.: R-3

APPROVED BY: COUNTY ENGINEER

FIGURE - 4A

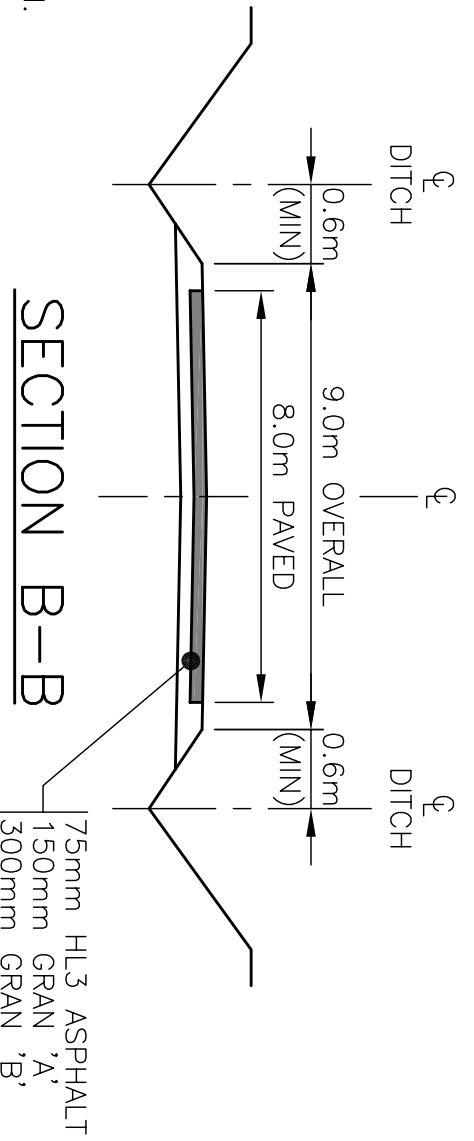
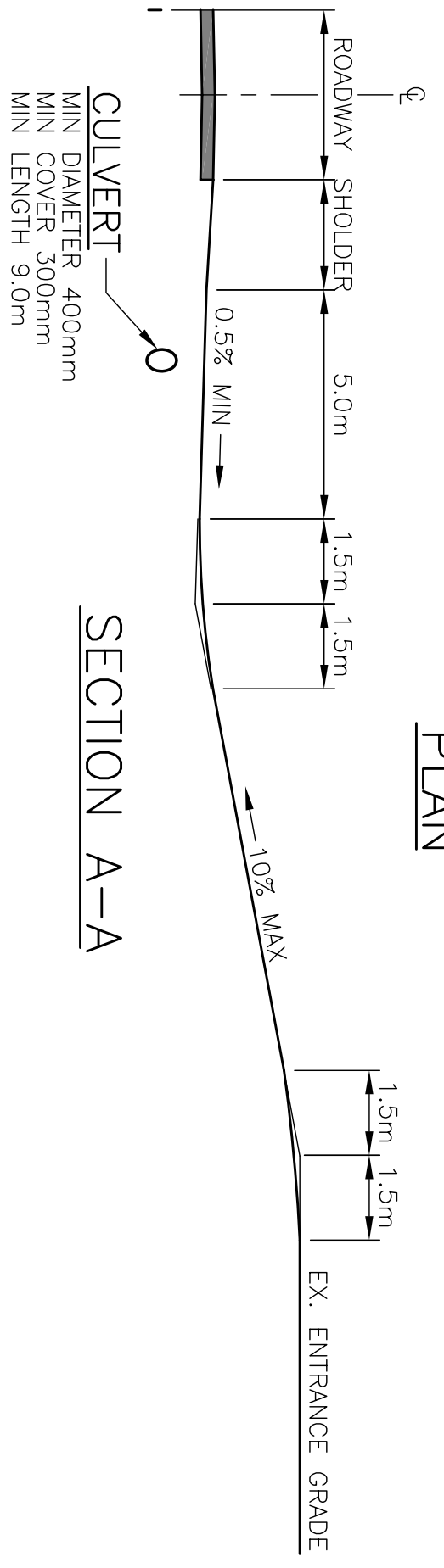
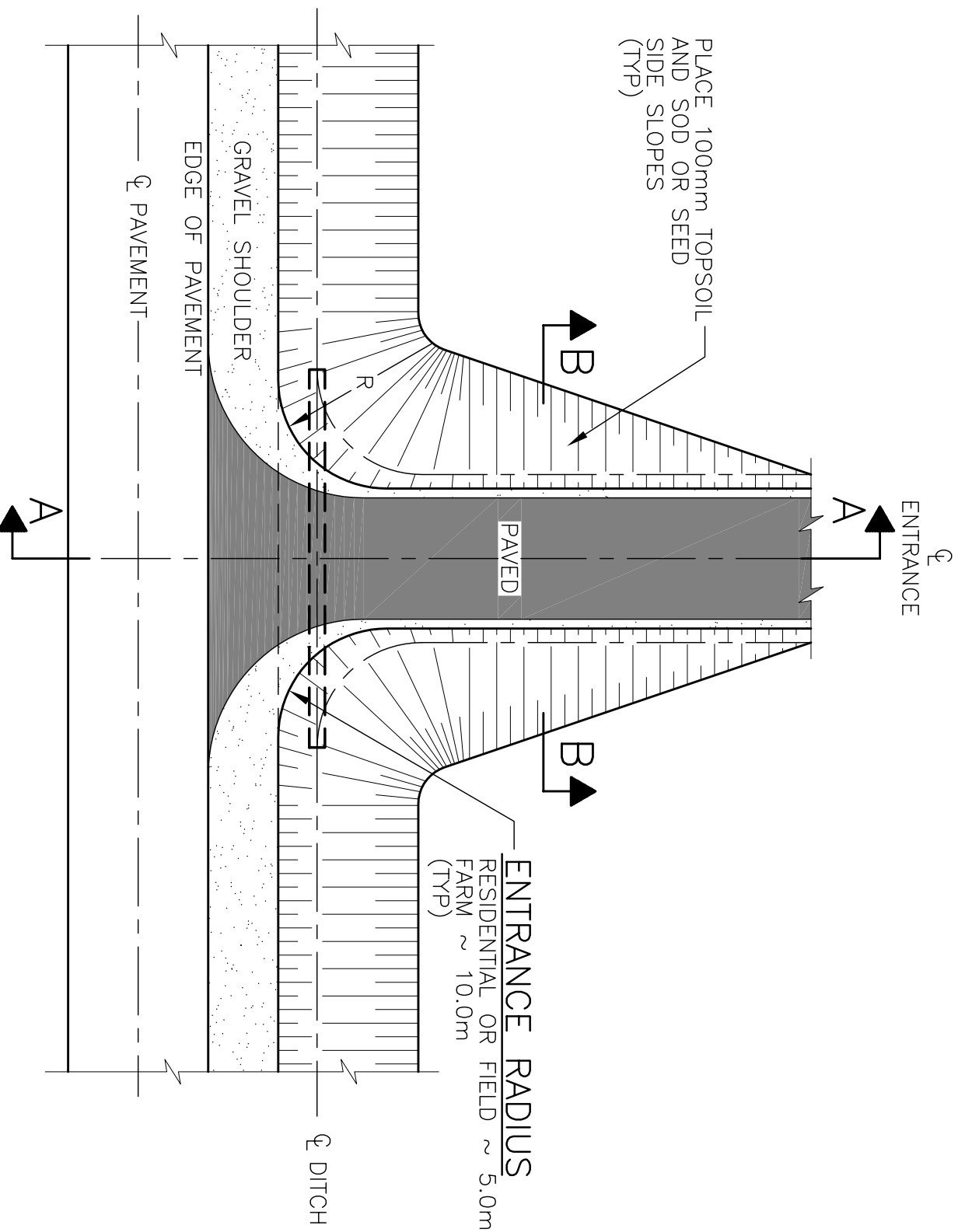

**NOTE:**  
 ALL DIMENSIONS ARE IN MILLIMETRES OR METRES UNLESS OTHERWISE SHOWN.

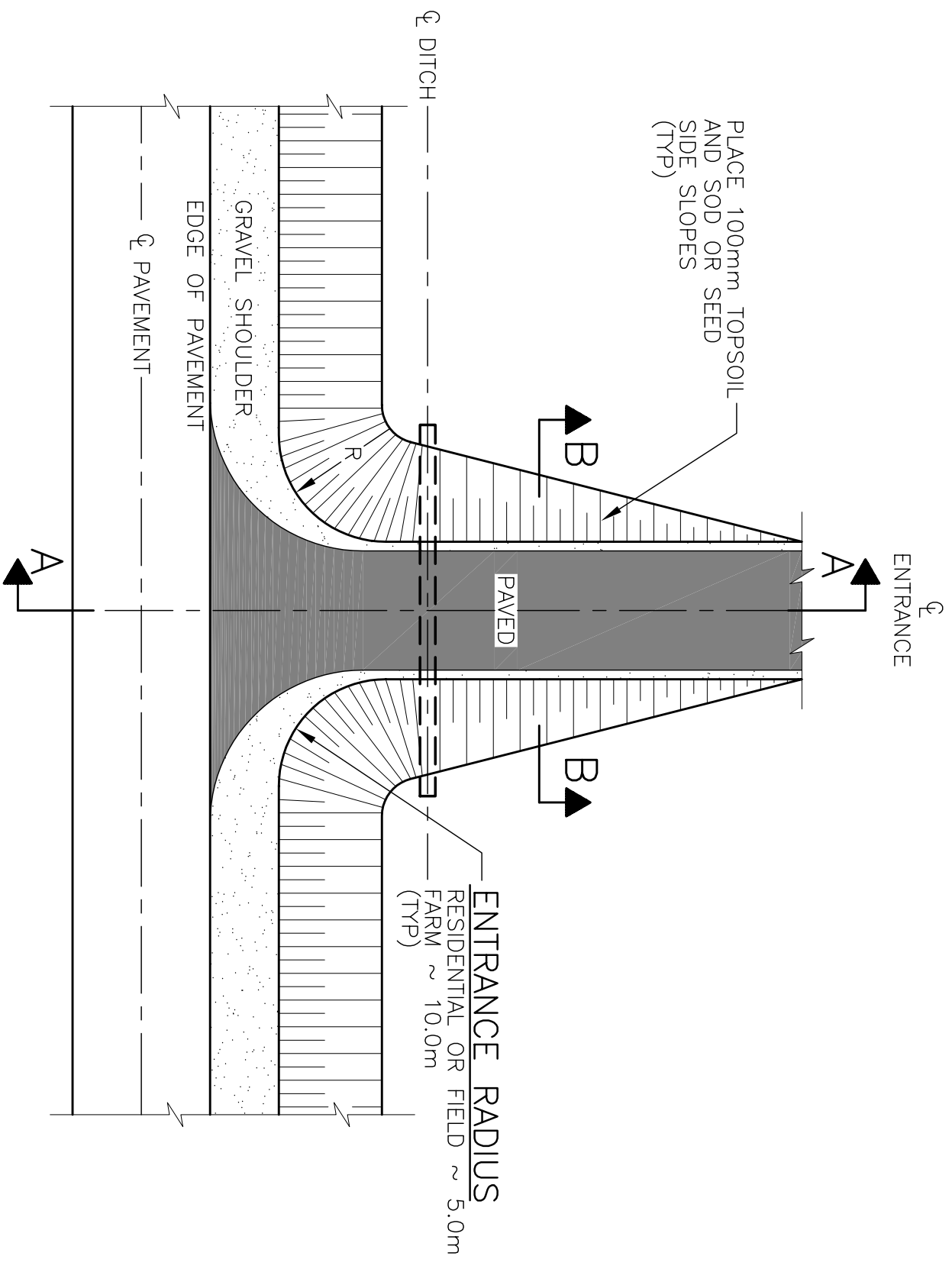

PLAN

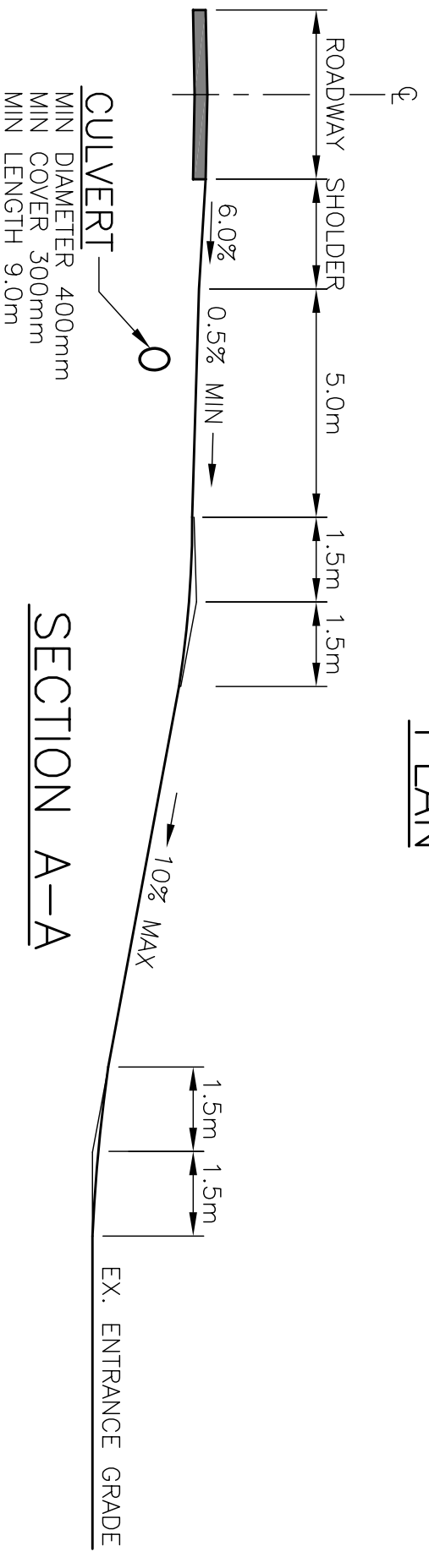

SECTION A-A

**NOTE:**  
ALL DIMENSIONS ARE IN MILLIMETRES OR METRES UNLESS OTHERWISE SHOWN.

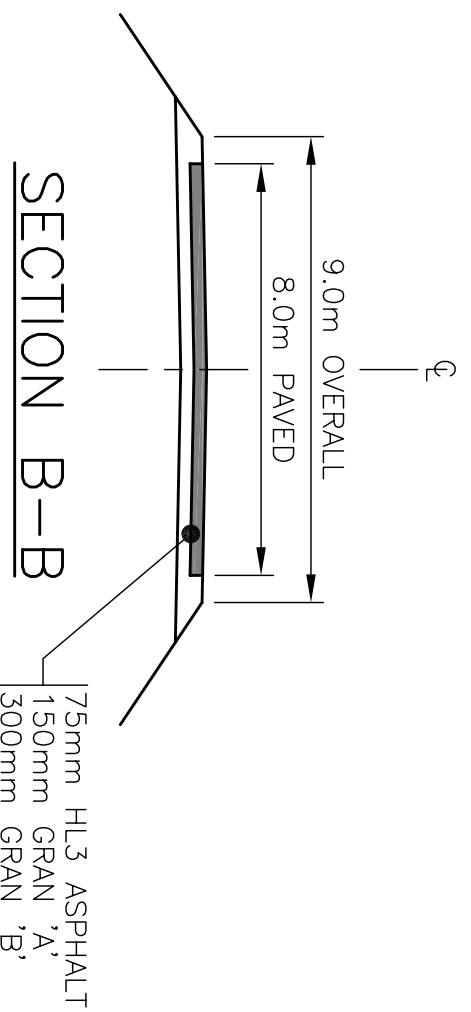

SECTION B-B

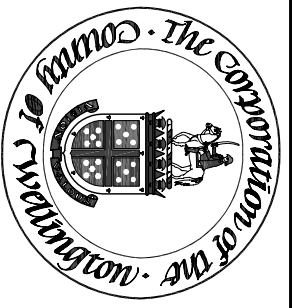

COUNTY OF WELLINGTON STANDARD DRAWING

DATE DRAWN: JANUARY 2006  
REV. No.: R-3

COUNTY ENGINEER

EARTH FILL ENTRANCE TO  
COMMERCIAL, INDUSTRIAL  
AND INSTITUTIONAL

FIGURE - 4B

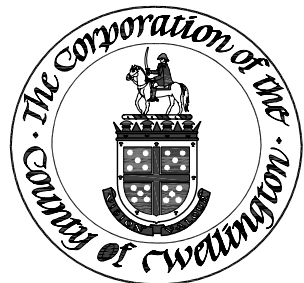
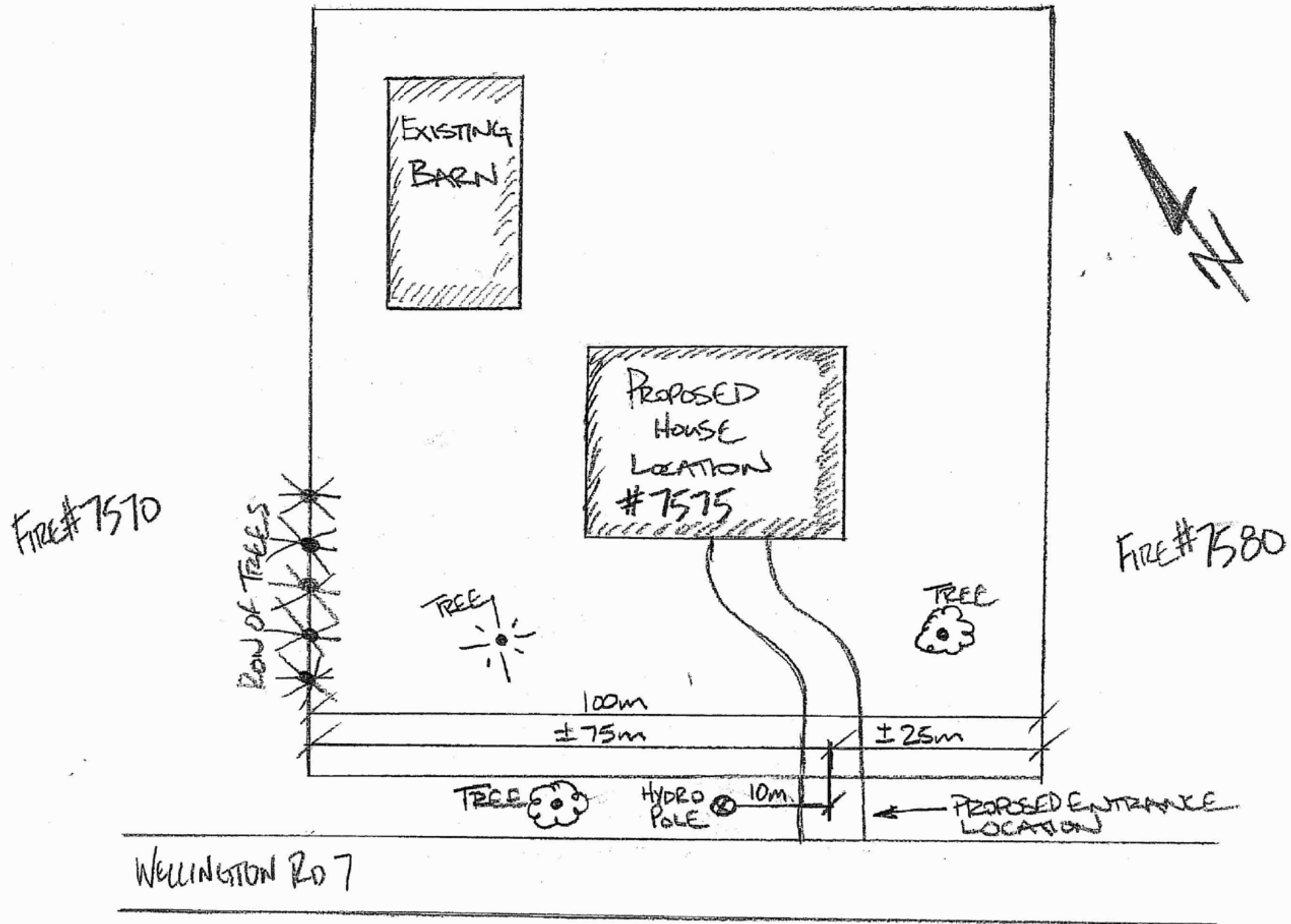

COUNTY OF WELLINGTON STANDARD DRAWING

DATE DRAWN:  
JANUARY 2007

REV. No.:  
R-1

EXAMPLE ENTRANCE  
SKETCH

APPROVED BY:

-----  
COUNTY ENGINEER

FIGURE - 5

PROPOSED

ENTRANCE